

**FLEXIBLE STAINLESS
STEEL HOSES
FOR FLUIDS AND
GASES**

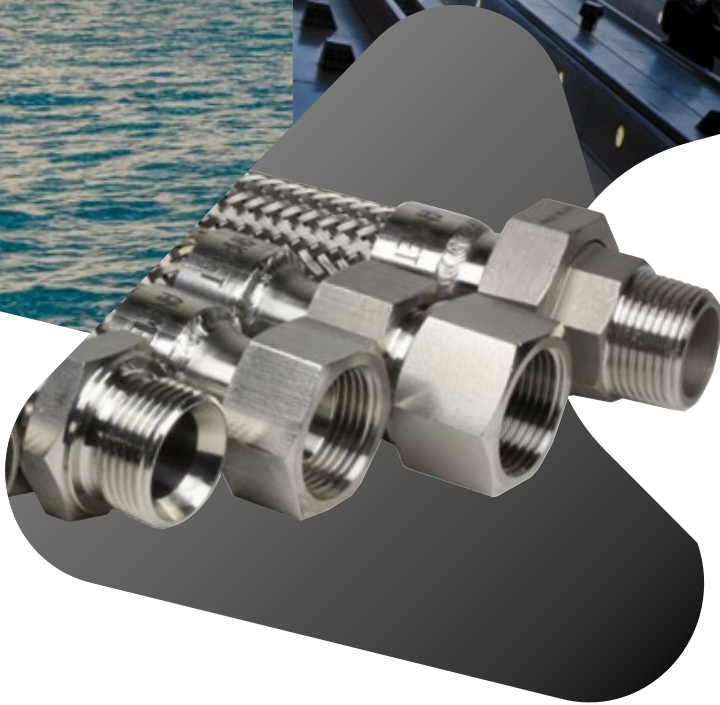

**TO
CONNECT
AND
PROTECT**



CATALOGUE CONTENT

SUBJECT	ITEM	PAGE
GENERAL	Content page	1 3
	Company profile	1 4
METAL HOSE	Hose selection table	1 12
	Engineering data general	1 13
	BW656	1 16
	BW756	1 18
	BW856	1 19
	BW956	1 21
	BW673	1 22
	Braid	1 23
	End connections	1 24
	Anaflex	1 37
	Anaflex-Click	1 38
	Type UIG	1 40
Type UI	1 41	
HEATPROTECTION	Hiprojacket Aero red	1 42
	Hiprojacket Industrial red	1 43
	Hiprotape red	1 44
TECHNICAL DATA	Installation hose assembly	1 45
	Engineering data	1 46
	Corrosion resistance table	1 49
	Product examples	1 53





Company profile

Anamet Europe BV is a specialist in the field of flexible hoses for the transfer of fluids and gases as well as conduit systems for the protection of electrical cables. As a part of Anamet Inc. we are able to service and support our customers worldwide with our specialism and solve all sorts of technical problems with the installation and protection of hoses, piping and cables in a variety of applications.

As a manufacturer of these systems we are not only able to supply the necessary components but are also able to deliver assembled products fully in accordance with your specifications. For over 70 years we have supplied flexible hose systems into steelworks, power plants, machine builders, trains, automotive, oil & gas, military and food equipment. This experience and our drive to work closely together with our customers to find the optimum solution to their needs has made us a specialist in flexible hose connections.



Quality

By the implementation of a quality system based on the international standard ISO 9001:2015 we do not only assure that our products fully comply to your requirements, but also that we are continuously working to improve our internal processes and service levels to enable us to satisfy your highest demands. Our manufacturing facility is located in Amsterdam, the Netherlands. Our production conforms to the latest standards and is executed by highly qualified personnel.

Design

Do you have a problem in the field of flexible connections? Be sure to make the right choice, not by simply selecting a supplier, but by selecting the right "partner". Choose for Anamet Europe BV. A team of well trained and enthusiastic engineers is waiting to assist you. By using Computer Aided Design in combination with the various research- and test methods in our laboratory, we will jointly define the best solution to your problem.



Product facilities

In our production facility in Amsterdam we avail of a wide range of production- and test equipment. We can provide mechanical machining such as cutting, rolling, grinding, winding, braiding, drilling and turning but also connecting techniques such as TIG- and MIG welding, spot welding, glueing, soldering and crimping.

With our qualified production workers we are able to manufacture and supply the full range of metal hoses according to customer specifications. Whether these are large series of standard hoses for the building and construction industry or highly qualified single hoses for specialistic applications in the petrochemical industry, in diameters from 1/4" up/incl. 14", in stainless steel, bronze or monel; we stand ready to serve you.



Stainless steel metal hoses

Anamet Europe B.V. corrugated stainless steel metal hoses have various industrial applications where high demands are set for movement, absorption of vibration or compensation to misalignment of piping systems.

The advantage of stainless steel metal hoses compared to rubber and plastic hoses are the high temperature resistance of $-200\text{ }^{\circ}\text{C}$ till $+600\text{ }^{\circ}\text{C}$ as well as their chemical resistance to many aggressive fluids and gasses. They are diffuse tight and not sensitive for aging. These specific characteristics in combination with our design capabilities make our products into one of the most reliable flexible connections. Metal hoses are often used under extreme conditions. To prevent premature failure we can supply many optional accessories like protective casing, spring wire, isolation, shrink sleeve, liners or heat protection covers. Our metal hoses can be delivered according to PED up to category III.

Anaconda Sealtite products

One of the best known products of Anamet worldwide, is the Anaconda Sealtite conduit, which in combination with a broad range of Anaconda fittings, provides a durable and liquid tight protection for cabling in a variety of applications. Anaconda Sealtite, a flexible liquid tight conduit, consisting of a spirally wound interlocking metal inner core with an extruded liquid tight cover, is available in a wide range of variations.



Whether you need protection against oil, dust, chemicals, heat and cold, radiation, explosive environments, shielding against EMC, zero halogen covers, or just mechanical protection and ease of installation, we have a solution for every specific need. For high demand markets like the train industry, nuclear power plants, military or shipbuilding we have specific solutions. These products are tested and approved for each of these specific application areas. As the environment is an important issue for us, we offer a full range, produced worldwide in conformity to the European guideline RoHS. We also have a range of products approved by the Underwriters Lab. and Canadian Standard Association for equipment that is exported to the USA or Canada.

In addition we have a full range of non-covered metal conduits and a full plastic-line (with e.g. polyamide) and a complete range of matching fittings and accessories for each of the conduits in our program. Unique are our Anaflex click fittings, power- and proximity switch adapters, stainless steel fittings in straight, 45° and 90° as well our ATEX approved explosion proof fittings. The majority of the products in our program are available from stock. Our team of experts stands ready at any time, to give you advice on the most suitable product for your specific application, thus providing you with the best guarantee for the continuation of your production processes.



Heat protective products









Anamet Europe invests in the continuous improvement of its flexible metal hoses solutions to deliver superior products that meet the precise requirements of its clients. It has developed a full range of sleeves, tapes, wraps and blankets in various qualities to protect against heat or provide insulation. Each is designed for use in custom solutions so you always find what you need for your market and your application. Our Hiprojacket sleeves and Hiproblankets can withstand temperatures from +260 °C continuously till +800 °C for approx. 20 minutes and even +1640 °C for 15-30 seconds. In addition we offer Thermojacket, made from woven glass fibre saturated with a high temperature resistant coating, which can withstand +538 °C on a continuous basis. These products are suitable for protection of cables and wires, hydraulic hoses and air piping against intense heat radiation and the hazard of molten metal splashes.



Anaconda **Metal hose**

Hose selection table

Anaconda corrugated metal hose

HOSE Type	MATERIAL Hose	MATERIAL Braid	SIZE (MM)		TEMP. (°C)		PRESSURE RATING	PAGE
			Min.	Max.	Min.	Max.		
BW 656 	Stainless steel AISI-316L	Stainless steel AISI-304	6	150	-70	+600	Standard up to medium	1-16
BW756 	Stainless steel AISI-316L	Stainless steel AISI-304	32	350	-70	+600	Medium	1-18
BW856 	Stainless steel AISI-316L	Stainless steel AISI-304	6	150	-70	+600	High	1-19
BW956 	Stainless steel AISI-316L	Stainless steel AISI-304	6	100	-70	+600	Extra High	1-21
BW673 	Monel 400	Monel 400	6	100	-50	+540	Standard up to medium	1-22
LOOSE BRAID 	-	Stainless steel AISI-304	6	100	-70	+600	Standard / Heavy	1-23
TYPE UIG 	Galvanised steel	-	5/16"	4"	-55	+300	-	1-37
TYPE UI 	Stainless steel AISI-304	-	5/16"	4"	-100	600	-	1-38
ANAFLEX 	Stainless steel AISI-316L	Stainless steel AISI-304	12	25	0	+250	Standard	1-42

The end connections for hoses BW 656, BW756, BW856, BW956 and BW673 are described on pages 1-16 till 1-22
The self-mountable fittings for ANAFLEX are described on page 1-37.

Next to our standard program, Anamet can supply their hose assemblies with a great variety of trade fittings, couplings, and custom designed fittings. Frequently used hose fixtures are: DIN 2353 L- and S-series fittings, SAE J/514 JIC 37° fittings, SAE 3000 and 6000 lbs flanges, DIN 11851 food couplings, Camlock coupling, Mann-tek Dry disconnect couplings and custom fittings according to drawing. Please contact our Fluid and Gases sales team for our comprehensive service.

This corrugated hose catalogue supersedes all previous corrugated hoses catalogues.
Information and technical details are subject to change without notification.

Engineering data general

CORRUGATED METAL HOSE

What it is, how it is made, where it is used...

Open pitch may be used where high flexibility is not essential. Pitch can affect flexibility and it varies from one manufacturer to another. Specifications on open pitch are available by contacting your ANAMET representative.

For higher pressure applications, one or more wire braid coverings are applied to the corrugated hose. Braiding prevents hose elongation under pressure, dampens vibration and provides some mechanical protection for the inner core. Two or more braids are available to increase pressure capabilities of certain corrugated product lines; however, the deformation pressure (a point where corrugation material would yield or elastically deform) governs the maximum working pressure regardless of the number of braid layers. A corrugated metal hose is defined as a length of tubing made flexible by forming convolutions so that it may be readily bent while remaining liquid- and gas-tight.

ANACONDA corrugated hose is made by thin wall tubing, corrugated into annular profiles. The annular hose profile is designed so that each convolution is a complete circle or ring in itself.

Corrugated hose is pressure tight and is particularly adapted to continuous flexing or vibration. It is available in closed pitch or open pitch. Closed pitch is standard, unless otherwise specified.

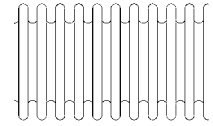

Open Pitch

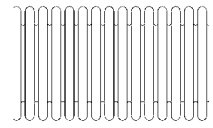

Closed Pitch

HOSE ASSEMBLY DESIGN CONSIDERATIONS

Flow velocity

Extremely high conveyant velocities in corrugated hose should be avoided as the corrugations could be forced into resonant vibration resulting in premature fatigue failure. Consult your ANAMET representative for applications involving flow velocities in excess of 35 m/s for braided hose and 6 m/s for unbraided hose.

Pressure

Pressure capabilities shown in the various hose tables are based on constant pressures. For pulsating or shock pressures consult your ANAMET representative.

Temperature

As the temperature of metal hose increases, the pressure capability decreases. The factors shown below should be used to adjust the pressure capabilities at higher temperatures.

TEMP. IN °C	STEEL	AISI-304	AISI-321	AISI-316L	MONEL	BRONZE
20/-200	-	1	1	1	1	1
20	1	1	1	1	1	1
50	0,97	0,88	0,92	0,88	0,94	0,95
100	0,91	0,73	0,83	0,74	0,86	0,86
150	0,84	0,66	0,78	0,67	0,81	0,82
200	0,77	0,60	0,74	0,62	0,77	0,75
250	0,71	0,56	0,71	0,58	0,75	-
300	0,65	0,52	0,67	0,54	0,74	-
350	0,60	0,50	0,64	0,52	0,74	-
400	0,57	0,48	0,62	0,50	0,74	-
450	0,29	0,47	0,61	0,48	0,73	-
500	0,18	0,46	0,60	0,47	-	-
550	-	0,42	0,59	0,47	-	-
600	-	-	-	-	-	-
650	-	-	-	-	-	-

Temperature correction factors

As the service temperature increases, a hose assembly maximum pressure rate decreases. The maximum allowable pressure of the hose assembly shall be the lowest of any method of assembly (mechanical, soldered, welded, silver brazed).

By using the factors given in the table on the right, the approximate safe working pressure, at elevated temperatures, can be calculated for assemblies with welded or mechanically attached fittings.

Example

Given: Maximum operating temperature 350°C
Maximum operating pressure 30 bar.

Determine: Is 20 mm BW656-1S (hose AISI 316L with braid AISI 304) with welded steel fittings satisfactory for the given operating conditions?
From the hose capability chart the working pressure for 20 mm BW656-1S is 70 bar.
The largest correction factor at 350°C is now determined, in this case 0,50 for the AISI 304 braid (see table).

Calculation: $70 \text{ bar} \times 0,50$ indicates an allowable working pressure of 35,0 bar at 350°C.

Solution: The hose BW656-1S will meet the required

Corrosion

Recommended alloy selection to provide satisfactory performance with various media can be found in the corrosion resistance table on page 1-49.

MOTION MOVEMENT

Length

The active or exposed length of a hose assembly must be sufficient to meet the conditions of movement. Lengths shorter than suggested can result in premature fatigue failure. Length tolerances as per our Quality Assurance Programme.

Bend Radius

The bend radius shown in the various hose tables are adequate to meet most industrial flexing requirements. Consideration should be given to those applications involving levels of high frequency or large amounts of travel by increasing the bend radius. Avoid sharp bends except where the installation is permanent and no additional flexing is expected. To prevent overbending of the hose, an overall casing can be used.

Installation Precautions

Hose assemblies must be installed so that all motion/movement is in the bending plane. Metal hose when flexed out of its bending plane will be subjected to torsion/twisting which develops a shear stress that can result in produce early hose failure. Braided hose must not be subjected to axial motion. Extension will result in preloading the braid. Compression will cause braid slack and can result in squirm of the corrugated core.

Abrasion

Allow for sufficient clearance so that hose in motion will not come in contact with adjacent objects. Where abrasion cannot be avoided, an overall casing is required to protect the hose from external damage.

Safety factor

We suggest that the maximum working pressures be no more than 25% of the rated burst pressure of the hose assembly after correcting for service temperature. Circumstances may require safety factors greater than 4 :1.

Testing

Depending on diameter, length, pressure, type of hose and end fitting design, hose assemblies are tested in various ways. It is ANAMET's standard practice to test assemblies by using one or more of the following methods: vacuum, hydrostatic, pneumatic or dye penetrant. Test media include: air, nitrogen, helium, water or oil. If special testing is required, it must be detailed at the time of an inquiry.

Tolerances

The standard tolerances used by ANAMET are found to be acceptable by most users. When tolerance considerations are critical, consult your ANAMET representative.

Cleaning

Depending on the medium being conveyed, special cleaning practices are sometimes necessary. ANAMET has special cleaning procedures where cleaning to standard commercial levels is not acceptable. Where special cleaning is necessary, requirements must be clearly specified.

End connections

The use of flexible metal hose is complimented by the extensive range of end connections that are available. Such end connetions may be male or female pipe threads, unions, flanges, flared tube fittings or other specially designed connectors. End connections are attached by welding, silver brazing, soldering and occasionally by mechanical means, depending on the type of hose and the alloy. In this catalogue a selection of various end connections are mentioned. For further detail or end connections that are not listed in the catalogue, please consult your ANAMET representative.

Standard up to medium pressure

BW656



Anaconda butt welded corrugated stainless steel hose type BW656 is designed for conveying chemicals, gases, steam, etc. It is suitable for use under full vacuum and has a temperature range of cryogenic to ca. +600°C*. Type BW656 is designed for general purpose service and will meet most pressure requirements. It has a good flexibility and a good flexural strength, suitable for normal industrial vibrations

Burst pressure: The burst pressure of hose with braid is at least 4 times the working pressure.

Material specifications: The core is manufactured from stainless steel AISI 316L (1.4404) with a standard stainless steel AISI 304 (1.4301) wire braid covering. Other alloys are available; consult your Anamet representative.

Types:

- BW 656-0 corrugated stainless steel hose, unbraided
- BW 656-1S corrugated stainless steel hose, with one standard braid
- BW 656-2S corrugated stainless steel hose, with two standard braids

NOMINAL I.D.		TYPE	MAX	MIN C/L BENDING RADIUS**		MIN. EXPOSED LENGTH FOR NORMAL VIBRATION (MM)	RATED PRESSURE DATA AT 20 °C***		APPROX. WEIGHT (KG/M)
(mm)	(inch)		O.D. (mm)	Flexing bend (mm)	Permanent bend (mm)		Max working pressure (bar)	Max test pressure (bar)	
6	1/4"	BW656-0	9,8	100	25	115	18	18	0,07
		BW656-1S	11,0				172	258	0,16
8	5/16"	BW656-0	12,4	100	25	125	18	18	0,09
		BW656-1S	13,6				120	180	0,19
10	3/8"	BW656-0	14,4	150	30	125	15	15	0,10
		BW656-1S	15,6				105	158	0,21
12	1/2"	BW656-0	16,9	180	35	140	12	12	0,11
		BW656-1S	18,5				95	143	0,31
15	1/2"	BW656-0	20,2	180	35	140	10	10	0,18
		BW656-1S	21,8				85	128	0,39
20	3/4"	BW656-0	27,0	190	40	150	7	7	0,25
		BW656-1S	28,6				70	105	0,54
25	1"	BW656-0	32,6	215	70	180	6	6	0,34
		BW656-1S	34,6				62	93	0,71
32	1.1/4"	BW656-0	41,4	230	90	205	4	4	0,50
		BW656-1S	44,2				48	72	0,99
40	1.1/2"	BW656-0	50,1	255	125	215	2	2	0,71
		BW656-1S	52,9				34	51	1,20
		BW656-2S	55,7				55	83	1,70
50	2"	BW656-0	60,8	280	190	240	1	1	0,85
		BW656-1S	63,6				28	42	1,47
		BW656-2S	66,4				35	53	2,09
65	2.1/2"	BW656-0	78,9	510	205	255	0,7	0,7	1,12
		BW656-1S	82,4				19	29	1,99
		BW656-2S	85,9				34	51	2,86

NOMINAL I.D.		TYPE	MAX	MIN C/L BENDING RADIUS**		MIN. EXPOSED LENGTH FOR NORMAL VIBRATION (MM)	RATED PRESSURE DATA AT 20 °C***		APPROX. WEIGHT (KG/M)
(mm)	(inch)		O.D. (mm)	Flexing bend (mm)	Permanent bend (mm)		Max working pressure (bar)	Max test pressure (bar)	
75	3"	BW656-0	96,0	560	230	280	0,7	0,7	1,50
		BW656-1S	100,3				25	38	3,00
		BW656-2S	104,6				32	48	4,50
100	4"	BW656-0	117,3	770	330	305	0,5	0,5	2,25
		BW656-1S	121,6				20	30	4,25
		BW656-2S	125,9				30	45	6,25
125	5"	BW656-0	146,3	1050	650	330	0,4	0,4	2,60
		BW656-1S	150,6				14	21	4,85
		BW756-2S	159,8				20	30	7,10
150	6"	BW656-0	171,5	1325	860	370	0,3	0,3	3,20
		BW656-1S	175,8				10	15	5,80
		BW756-2S	184,4				16	24	8,40

Note: for bigger sizes see type BW756 (page 1-18)

- * For working temperatures above 400°C environmental conditions are to be considered - consult your Anamet representative.
- ** It is recommendet to increase the minimum bend radius with 25% when high pressures or temperatures are involved.
- *** For temperatures higher than room temperature use the applicable temperature correction factor.

Medium pressure & larger sizes

BW756



Anaconda butt welded corrugated stainless steel hose type BW756 is designed for conveying chemicals, gases, steam, etc. It is suitable for use under full vacuum and has a temperature range of cryogenic to ca. +600°C*. Type BW756 will meet most pressure requirements and is also available in the bigger sizes up to 14". It has a good flexibility and a good flexure life, suitable for normal industrial vibrations.

Burst pressure: The burst pressure of hose with braid is at least 4 times the working pressure.

Material specifications: The core is manufactured from stainless steel AISI 316L (1.4404) with a heavy stainless steel AISI 304 (1.4301) wire braid covering. Other alloys are available; consult your Anamet representative.

Types:

- BW756-0 corrugated stainless steel hose, unbraidedw
- BW756-1H corrugated stainless steel hose, with one heavy braid

NOMINAL I.D.		TYPE	MAX O.D. (MM)	MIN C/L BENDING RADIUS**		MIN. EXPOSED LENGTH FOR NORMAL VIBRATION (MM)	RATED PRESSURE DATA AT 20 °C***		APPROX. WEIGHT (KG/M)
(mm)	(inch)			Flexing bend (mm)	Permanent bend (mm)		Max working pressure (bar)	Max test pressure (bar)	
32	1.1/4"	BW756-0	47,8	270	90	205	2	2	1,13
		BW756-1H	50,6				55	83	1,88
40	1.1/2"	BW756-0	56,4	305	105	215	1	1	1,25
		BW756-1H	59,9				52	78	2,29
50	2"	BW756-0	66,9	380	130	240	1	1	1,34
		BW756-1H	70,4				50	75	2,72
65	2.1/2"	BW756-0	83,0	510	205	255	0,7	0,7	1,73
		BW756-1H	87,3				38	57	3,31
75	3"	BW756-0	97,0	560	230	280	0,7	0,7	1,80
		BW756-1H	101,3				34	51	3,67
100	4"	BW756-0	124,2	685	330	305	0,5	0,5	2,51
		BW756-1H	128,5				24	36	4,67
125	5"	BW756-0	151,2	790	455	330	0,4	0,4	3,72
		BW756-1H	155,3				20	30	6,42
150	6"	BW756-0	175,8	915	485	370	0,3	0,3	5,16
		BW756-1H	180,1				18	27	9,04
200	8"	BW756-0	234,1	1015	510	490	0,3	0,3	8,27
		BW756-1H	238,4				16	24	14,04
250	10"	BW756-0	286,5	1270	635	670	0,3	0,3	10,12
		BW756-1H	292,0				16	24	19,19
300	12"	BW756-0	339,0	1525	765	940	0,2	0,2	13,42
		BW756-1H	345,0				11	17	22,06
350	14"	BW756-0	376,0	1780	890	1350	0,2	0,2	20,98
		BW756-1H	383,0				8	12	32,28

* For working temperatures above 400°C environmental conditions are to be considered - consult your Anamet representative.

** It is recommendet to increase the minimum bend radius with 25% when high pressures or temperatures are involved.

*** For temperatures higher than room temperature use the applicable temperature correction factor.

High pressure

BW856



Anaconda butt welded corrugated stainless steel hose type BW856 is designed for conveying chemicals, gases, steam, etc. It is suitable for use under full vacuum and as a temperature range of cryogenic to ca. +600°C*. Type BW856 engineered design and construction allows it to operate at higher pressures than the standard and medium series. Its durable construction makes it suitable for severe applications, vibrations and high pressures.

Burst pressure: The burst pressure of hose with braid is at least 4 times the working pressure.

Material specifications: The core is manufactured from AISI 316 L (1.4404) stainless steel with a heavy stainless steel AISI 304 (1.4301) wire braid covering. Other alloys are available; consult your Anamet representative.

Types:

- BW856-0 corrugated stainless steel hose, unbraided
- BW856-1H corrugated stainless steel hose, with one heavy braid
- BW856-2H corrugated stainless steel hose, with two heavy braids

NOMINAL I.D.		TYPE	MAX O.D. (MM)	MIN C/L BENDING RADIUS**		MIN. EXPOSED LENGTH FOR NORMAL VIBRATION (MM)	RATED PRESSURE DATA AT 20 °C***		APPROX. WEIGHT (KG/M)
(mm)	(inch)			Flexing bend (mm)	Permanent bend (mm)		Max working pressure (bar)	Max test pressure (bar)	
6	1/4"	BW856-0	10,5	140	25	115	12	12	0,15
		BW856-1H	11,9				230	345	0,26
		BW856-2H	13,3				275	413	0,37
10	3/8"	BW856-0	16,4	205	40	125	7	7	0,30
		BW856-1H	18,4				150	225	0,50
		BW856-2H	20,4				190	285	0,70
12	1/2"	BW856-0	21,4	205	40	140	6	6	0,58
		BW856-1H	24,0				132	198	0,89
		BW856-2H	26,6				225	338	1,20
20	3/4"	BW856-0	31,3	205	55	150	5	5	1,07
		BW856-1H	34,1				90	135	1,51
		BW856-2H	36,9				145	218	1,95
25	1"	BW856-0	38,7	230	80	180	3	3	1,37
		BW856-1H	41,5				85	128	2,03
		BW856-2H	44,3				118	177	2,69
32	1.1/4"	BW856-0	47,8	255	85	205	2	2	1,89
		BW856-1H	50,6				64	96	2,64
		BW856-2H	53,4				112	168	3,39
40	1.1/2"	BW856-0	56,4	255	85	215	1	1	1,92
		BW856-1H	59,9				60	90	2,96
		BW856-2H	63,4				96	144	4,00
50	2"	BW856-0	64,8	295	140	240	1	1	1,90
		BW856-1H	68,3				55	83	3,36
		BW856-2H	71,8				85	128	4,74

HIGH PRESSURE - BW856

NOMINAL I.D.		TYPE	MAX O.D. (MM)	MIN C/L BENDING RADIUS**		MIN. EXPOSED LENGTH FOR NORMAL VIBRATION (MM)	RATED PRESSURE DATA AT 20 °C***		APPROX. WEIGHT (KG/M)
(mm)	(inch)			Flexing bend (mm)	Permanent bend (mm)		Max working pressure (bar)	Max test pressure (bar)	
65	2.1/2"	BW856-0	83,0	610	180	255	0,7	0,7	3,19
		BW856-1H	87,3				38	57	4,77
		BW856-2H	91,6				64	96	6,35
75	3"	BW856-0	97,0	715	195	280	0,7	0,7	5,12
		BW856-1H	101,3				34	51	7,01
		BW856-2H	105,6				55	83	8,90
100	4"	BW856-0	123,2	1020	510	305	0,5	0,5	4,65
		BW856-1H	127,5				24	36	6,81
		BW856-2H	131,8				35	53	8,97
150	6"	BW856-0	176,6	1220	610	370	0,3	0,3	5,38
		BW856-1H	180,9				18	27	9,26
		BW856-2H	185,2				28	42	13,14

* For working temperatures above 400°C environmental conditions are to be considered - consult your Anamet representative.

** It is recommendet to increase the minimum bend radius with 25% when high pressures or temperatures are involved.

*** For temperatures higher than room temperature use the applicable temperature correction factor.

Extra high pressure

BW956



ANACONDA butt welded corrugated stainless steel hose type BW956 is designed for conveying chemicals, gases, steam, etc. It is suitable for use under full vacuum and has a temperature range of cryogenic to ca. +600°C*. The engineered design and construction allows it to operate at higher pressures than the BW856 type. Its extra durable construction makes it suitable for severe applications, vibrations and extreme high pressures.

Burst pressure: The burst pressure of hose with braid is at least 4 times the working pressure.

Material specifications: The core is manufactured from AISI 316L (1.4404) stainless steel with an extra heavy stainless steel AISI 304 (1.4301) wire braid covering. Other alloys are available; consult your Anamet representative.

Types:

- BW956-0 corrugated stainless steel hose, unbraided
- BW956-2E corrugated stainless steel hose, with two extra heavy braids
- BW956-2F corrugated stainless steel hose, with two extra heavy braids

NOMINAL I.D.		TYPE	MAX O.D. (MM)	MIN C/L BENDING RADIUS**		MIN. EXPOSED LENGTH FOR NORMAL VIBRATION (MM)	RATED PRESSURE DATA AT 20 °C***		APPROX. WEIGHT (KG/M)
(mm)	(inch)			Flexing bend (mm)	Permanent bend (mm)		Max working pressure (bar)	Max test pressure (bar)	
6	1/4"	BW956-0	13,1	305	155	115	12	12	0,30
		BW956-2E	17,9				310	465	0,61
10	3/8"	BW956-0	17,4	305	155	125	7	7	0,46
		BW956-2E	22,6				270	405	0,97
12	1/2"	BW956-0	21,4	330	180	140	6	6	0,73
		BW956-2E	27,0				255	383	1,48
20	3/4"	BW956-0	31,3	380	190	150	5	5	1,35
		BW956-2E	36,9				185	278	2,45
25	1"	BW956-0	38,7	410	205	180	3	3	1,66
		BW956-2E	44,3				158	237	3,07
32	1.1/4"	BW956-0	47,8	460	220	205	2	2	2,58
		BW956-2E	53,8				132	198	4,37
40	1.1/2"	BW956-0	56,4	485	245	215	1	1	3,84
		BW956-2E	63,4				120	180	6,26
50	2"	BW956-0	64,2	610	305	240	1	1	4,98
		BW956-2E	71,8				92	138	7,94
65	2.1/2"	BW956-0	83,0	690	340	255	0,7	0,7	5,07
		BW956-2E	91,6				70	105	8,54
75	3"	BW956-0	97,0	815	435	280	0,7	0,7	6,53
		BW956-3E	110,0				65	98	12,20
100	4"	BW956-0	123,2	1220	560	305	0,5	0,5	7,07
		BW956-3E	136,2				45	68	13,55

* For working temperatures above 400°C environmental conditions are to be considered - consult your Anamet representative.

** It is recommendet to increase the minimum bend radius with 25% when high pressures or temperatures are involved.

*** For temperatures higher than room temperature use the applicable temperature correction factor.

Extreme corrosion resistant

BW673

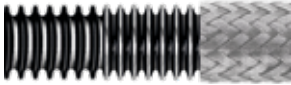

ANACONDA type BW673 is extremely resistant to corrosion, and is used to convey corrosive liquids and gases for applications that involve high pressure, temperatures up to +540 °C*, vibration and flexure. Type BW673 is designed for Chlorine applications. Applicable as transfer hose for tankcar, cargotank, tankbarge, etc.

Burst pressure: The burst pressure of hose with braid is at least 4 times the working pressure.

Material specifications: The hose and braid are manufactured from Monel 400. For other alloys please consult your Anamet representative.

Types:

- BW673-0 corrugated Monel hose, unbraided
- BW673-1S corrugated Monel hose, with one Monel braid
- BW673-2S corrugated Monel hose, with two Monel braids

NOMINAL I.D.		TYPE	MAX O.D. (MM)	MIN C/L BENDING RADIUS**		MIN. EXPOSED LENGTH FOR NORMAL VIBRATION (MM)	RATED PRESSURE DATA AT 20 °C***		APPROX. WEIGHT (KG/M)
(mm)	(inch)			Flexing bend (mm)	Permanent bend (mm)		Max working pressure (bar)	Max test pressure (bar)	
6	1/4"	BW673-0	11,9	155	50	115	9	13,4	0,19
		BW673-1S	13,4				117	176	0,31
		BW673-2S	14,7				167	250	0,43
10	3/8"	BW673-0	15,7	155	50	125	6,2	9,3	0,23
		BW673-1S	17,2				88	132	0,40
		BW673-2S	18,7				135	202	0,60
12	1/2"	BW673-0	19,5	180	65	140	4,5	6,8	0,28
		BW673-1S	20,8				59	88	0,46
		BW673-2S	22,3				93	139	0,64
20	3/4"	BW673-0	27,0	205	65	150	3,4	5,2	0,41
		BW673-1S	28,2				49	73	0,64
		BW673-2S	29,7				80	120	0,89
25	1"	BW673-0	34,5	230	75	180	2,4	3,6	0,74
		BW673-1S	36,3				48	72	1,15
		BW673-2S	38,4				78	117	1,61
32	1.1/4"	BW673-0	44,7	255	105	205	1,4	2,1	0,95
		BW673-1S	47,5				42	63	1,46
		BW673-2S	49,5				68	102	2,02
40	1.1/2"	BW673-0	53,3	255	105	215	1	1,5	1,16
		BW673-1S	55,2				29	43	1,76
		BW673-2S	57,3				53	79	2,41
50	2"	BW673-0	64,9	280	155	240	0,7	1	1,44
		BW673-1S	67,2				22	32	2,16
		BW673-2S	69,7				42	64	2,96
75	3"	BW673-0	98,3	510	255	280	0,5	0,7	2,63
		BW673-1S	102,4				21	31	3,97
		BW673-2S	105,4				34	52	5,46
100	4"	BW673-0	122,3	610	305	305	0,3	0,4	3,10
		BW673-1S	127,3				18	27	5,27
		BW673-2S	132,3				30	45	7,69

* For working temperatures above 400°C environmental conditions are to be considered - consult your Anamet representative.

** It is recommendet to increase the minimum bend radius with 25% when high pressures or temperatures are involved.

*** For temperatures higher than room temperature use the applicable temperature correction factor.

Stainless steel braiding

BRAID



Anaconda braid type S (standard braid) and H (heavy braid) are mainly supplied in combination with our Anaconda butt-welded corrugated hoses type BW656, BW756, BW856 and BW956. However they can also be obtained as loose braids.

Burst pressure: The burst pressure of hose with braid is at least 4 times the working pressure.

Material specifications: The braids are manufactured from stainless steel AISI 304 (1.4301) wire. Other alloys are available; consult your Anamet representative.

Types:

- S Standard braid
- H Heavy braid
- E Extra heavy braid (on demand)

FOR HOSE I.D.		TYPE	CORE DIAMETRE (MM)	BRAID CONSTRUCTION			COVERAGE GRADE %	RATED PRESSURE DATA AT 20 °C***		APPROX. WEIGHT (KG/M)
(mm)	(inch)			Number of Strands	Wires per Strand	Wire diam. (mm)		Max. working pressure (bar)	Max. test pressure (bar)	
6	1/4"	1S	9,8	32	4	0,3	89	172	258	0,09
8	5/16"	1S	12,4	32	4	0,3	83	120	180	0,10
10	3/8"	1S	14,4	32	5	0,3	83	105	158	0,11
15	1/2"	1S	20,2	32	5	0,4	88	85	128	0,21
20	3/4"	1S	27,0	32	7	0,4	87	70	105	0,29
25	1"	1S	32,6	48	6	0,4	92	62	93	0,37
32	1.1/4"	1S	41,4	48	8	0,4	93	48	72	0,49
40	1.1/2"	1S	50,1	48	8	0,4	87	34	51	0,49
50	2"	1S	60,8	48	10	0,4	83	28	42	0,62
65	2.1/2"	1S	78,9	48	8	0,5	80	19	29	0,87
75	3"	1S	96,0	48	9	0,63	86	25	38	1,50
100	4"	1S	117,3	48	12	0,63	86	20	30	2,00
125	5"	1S	146,3	72	8	0,63	74	14	21	2,25
150	6"	1S	171,5	72	10	0,63	74	10	15	2,60

FOR HOSE I.D.		TYPE	CORE DIAMETRE (MM)	BRAID CONSTRUCTION			COVERAGE GRADE %	RATED PRESSURE DATA AT 20 °C***		APPROX. WEIGHT (KG/M)
(mm)	(inch)			Number of Strands	Wires per Strand	Wire diam. (mm)		Max. working pressure (bar)	Max. test pressure (bar)	
6	1/4"	1H	10,5	32	5	0,3	95	230	345	0,11
10	3/8"	1H	16,4	32	5	0,4	94	150	225	0,20
12	1/2"	1H	21,4	32	5	0,5	96	132	198	0,31
20	3/4"	1H	31,4	32	7	0,5	95	90	135	0,44
25	1"	1H	38,9	48	7	0,5	99	85	128	0,66
32	1.1/4"	1H	47,8	48	8	0,5	99	64	96	0,75
40	1.1/2"	1H	56,4	48	7	0,63	98	60	90	1,04
50	2"	1H	64,8	48	9	0,63	97	55	83	1,38
65	2.1/2"	1H	83,0	48	10	0,63	96	38	57	1,58
75	3"	1H	97,0	48	12	0,63	96	34	51	1,89
100	4"	1H	123,4	72	9	0,63	89	24	36	2,16
150	6"	1H	176,6	96	13	0,63	89	18	27	3,88

*** The rated pressure data are based on the combination with Anaconda hoses. For other combinations or other applications, please contact Anamet Europe B.V. for specific braid calculation.

End connections



STANDARD END CONNECTIONS FIGURES

Figure 1 to 14 show the standard Anamet hose end connections.

All connections are TIG-welded onto our corrugated hoses. Weld oxides can be removed by brushing with a plastic wire brush or by electrolytic cleaning (to be specified on order).

Fig. 1

Welding end, hose Id. 1/4" to 4".
- Carbon steel / Stainless steel

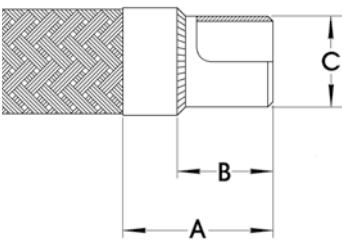

HOSE NOMINAL ID		DIMENSIONS IN MM			*C ANSI	*C ISO
(mm)	(inch)	A	B	C		
6	1/4"	59	50	-	13,7 x 2,2	10,2 x 1,6 / 13,5 x 1,8
10	3/8"	60	50	-	17,2 x 2,3	17,2 x 1,8
12	1/2"	62	50	-	21,3 x 2,8	21,3 x 2,0
20	3/4"	65	50	-	26,7 x 2,9	26,9 x 2,3
25	1"	70	50	-	33,4 x 3,4	33,7 x 2,6
32	1.1/4"	70	50	-	42,2 x 3,6	42,4 x 2,6
40	1.1/2"	85	60	-	48,3 x 3,7	48,3 x 2,6
50	2"	90	60	-	60,3 x 3,9	60,3 x 2,9
65	2.1/2"	90	60	-	73,0 x 5,2	76,1 x 2,9
75	3"	95	65	-	88,9 x 5,5	88,9 x 3,2
100	4"	105	75	-	114,3 x 6,0	114,3 x 3,6

* If fittings with other dimension "C" are required please specify when ordering.

Fig. 2

Welding end, hose Id. 5" to 8".
- Carbon steel / Stainless steel

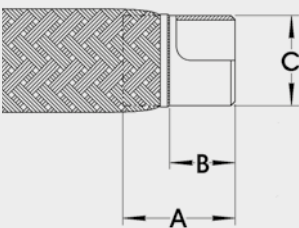

HOSE NOMINAL ID		DIMENSIONS IN MM			*C ANSI	*C ISO
(mm)	(inch)	A	B	C		
125	5"	125	75	-	141,3 x 6,5	139,7 x 4,0
150	6"	125	75	-	168,3 x 7,1	168,3 x 4,5
200	8"	135	75	-	219,1 x 8,2	219,1 x 5,9

END CONNECTIONS

Fig. 2

Pipe nipple male (tapered thread).
 - BSPT Stainless steel
 - NPT Carbon steel / Stainless steel

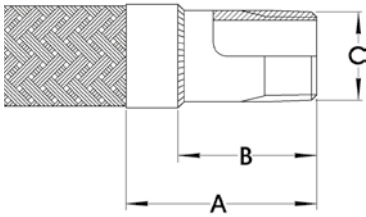

HOSE NOMINAL ID		DIMENSIONS IN MM			DIMENSIONS IN MM		
(mm)	(inch)	A	B	C	A	B	C
6	1/4"	38	29	1/4" BSPT	45	36	1/4" NPT
10	3/8"	39	29	3/8" BSPT	46	36	3/8" NPT
12	1/2"	52	40	1/2" BSPT	54	42	1/2" NPT
20	3/4"	55	40	3/4" BSPT	61	46	3/4" NPT
25	1"	70	50	1" BSPT	73	53	1" NPT
32	1 1/4"	75	55	1 1/4" BSPT	75	55	1 1/4" NPT
40	1 1/2"	85	60	1 1/2" BSPT	84	59	1 1/2" NPT
50	2"	95	65	2" BSPT	87	57	2" NPT
65	2 1/2"	105	75	2 1/2" BSPT	120	90	2 1/2" NPT
75	3"	105	75	3" BSPT	120	90	3" NPT
100	4"	125	95	4" BSPT	125	95	4" NPT

Fig. 3

Hexagon nipple male (tapered thread).
 - BSPT Stainless steel
 - NPT Carbon steel / Stainless steel

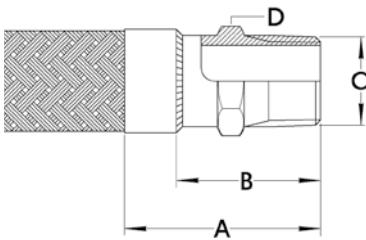

HOSE NOMINAL ID		DIMENSIONS IN MM			DIMENSIONS IN MM			
(mm)	(inch)	A	B	C	A	B	C	D
6	1/4"	33	24	1/4" BSPT	39	27	1/4" NPT	14
10	3/8"	38	28	3/8" BSPT	43	33	3/8" NPT	19
12	1/2"	46	34	1/2" BSPT	50	38	1/2" NPT	22
20	3/4"	55	40	3/4" BSPT	59	44	3/4" NPT	27
25	1"	66	46	1" BSPT	69	49	1" NPT	36
32	1 1/4"	72	52	1 1/4" BSPT	75	55	1 1/4" NPT	42
40	1 1/2"	79	54	1 1/2" BSPT	81	56	1 1/2" NPT	50
50	2"	92	62	2" BSPT	89	59	2" NPT	65
65	2 1/2"	103	73	2 1/2" BSPT				
75	3"	120	90	3" BSPT				
100	4"	130	100	4" BSPT				

Fig. 4

Hexagon nipple male. (parallel thread).
 60° cone seat + flat seat on hexagon,
 - BSPP Carbon steel / Stainless steel

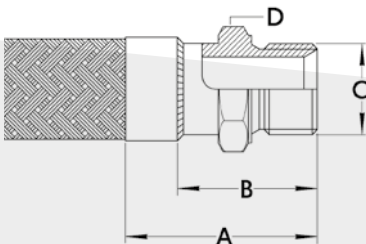

HOSE NOMINAL ID		DIMENSIONS IN MM			
(mm)	(inch)	A	B	C	D
6	1/4"	33	24	1/4" BSPP	17
10	3/8"	39	29	3/8" BSPP	22
12	1/2"	44	32	1/2" BSPP	27
20	3/4"	55	40	3/4" BSPP	32
25	1"	65	45	1" BSPP	41
32	1 1/4"	65	45	1 1/4" BSPP	50
40	1 1/2"	72	47	1 1/2" BSPP	55
50	2"	81	51	2" BSPP	70
65	2 1/2"	95	65	2 1/2" BSPP	85
75	3"	110	80	3" BSPP	100
100	4"	120	90	4" BSPP	135

* Hexagon nipple male is also available with flat seat instead of 60° cone seat.

END CONNECTIONS

Fig. 5

Round socket female.

- BSPP Stainless steel
- NPT Carbon steel / Stainless steel

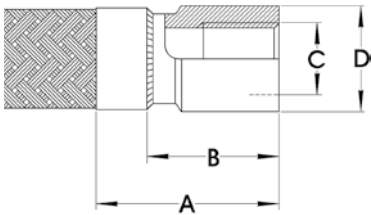

HOSE NOMINAL ID		DIMENSIONS IN MM				
(mm)	(inch)	A	B	C	D	C
6	1/4	36	27	1/4" BSPP	17	1/4" NPT
10	3/8	40	35	3/8" BSPP	22	3/8" NPT
12	1/2	52	40	1/2" BSPP	27	1/2" NPT
20	3/4	55	40	3/4" BSPP	33	3/4" NPT
25	1	70	50	1" BSPP	40	1" NPT
32	1.1/4	75	55	1.1/4" BSPP	50	1.1/4" NPT
40	1.1/2	85	60	1.1/2" BSPP	58	1.1/2" NPT
50	2	95	65	2" BSPP	70	2" NPT
65	2.1/2	104	74	2.1/2" BSPP	85	
75	3	110	80	3" BSPP	100	
100	4	124	94	4" BSPP	125	

Fig. 6

Hexagon socket female.

- BSPP Stainless steel
- NPT Stainless steel

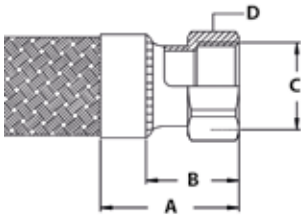

HOSE NOMINAL ID		DIMENSIONS IN MM			
(mm)	(inch)	A	B	C	D
6	1/4"	40,5	28,5	1/4" BSPP	30
10	3/8"	46	31	3/8" BSPP	35
12	1/2"	53	38	1/2" BSPP	42
20	3/4"	56	41	3/4" BSPP	47
25	1"	66	46	1" BSPP	53
32	1.1/4"	69	49	1.1/4" BSPP	71
40	1.1/2"	76	51	1.1/2" BSPP	78
50	2"	86	56	2" BSPP	92

Fig. 7

Sphere cone nipple with hexagon swivel nut.

- BSPP Carbon steel / Stainless steel

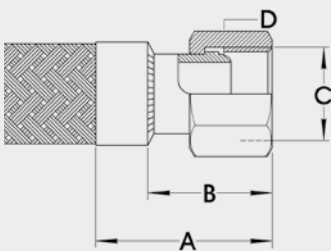

HOSE NOMINAL ID		DIMENSIONS IN MM			
(mm)	(inch)	A	B	C	D
6	1/4	37	28	1/4" BSPP	19
10	3/8	38	28	3/8" BSPP	22
12	1/2	40	28	1/2" BSPP	27
20	3/4	45	30	3/4" BSPP	32
25	1	54	34	1" BSPP	41
32	1.1/4	54	34	1.1/4" BSPP	50
40	1.1/2	59	34	1.1/2" BSPP	60
50	2	68	38	2" BSPP	70

* Spherical cone nipple standard is AISI-316L. Unless specified otherwise.

END CONNECTIONS

Fig. 7A

Sphere cone nipple with hexagon swivel nut (fig.7) with hexagon adapter BSPP female.

- Carbon steel / Stainless steel

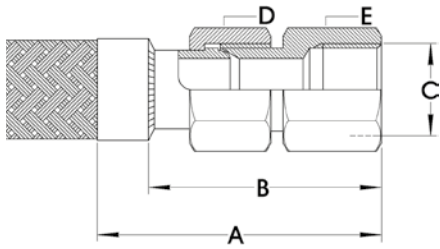

HOSE NOMINAL ID		DIMENSIONS IN MM				
(mm)	(inch)	A	B	C	D	E
6	1/4	64	55	1/4" BSPP	19	17
10	3/8	66	56	3/8" BSPP	22	22
12	1/2	71	59	1/2" BSPP	27	27
20	3/4	80	65	3/4" BSPP	32	32
25	1	93	73	1" BSPP	41	41
32	1.1/4	95	75	1.1/4" BSPP	50	50
40	1.1/2	102	77	1.1/2" BSPP	60	55
50	2	113	83	2" BSPP	70	70

Fig. 7B

Sphere cone nipple with hexagon swivel nut (fig.7) with hexagon adapter BSPP male (parallel thread).

- Carbon steel / Stainless steel

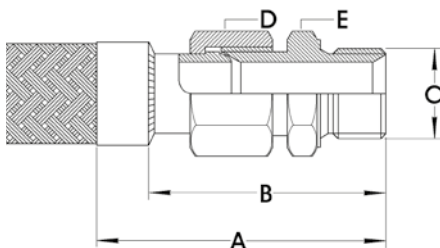

HOSE NOMINAL ID		DIMENSIONS IN MM				
(mm)	(inch)	A	B	C	D	E
6	1/4	59	50	1/4" BSPP	19	17
10	3/8	64	54	3/8" BSPP	22	22
12	1/2	72	60	1/2" BSPP	27	27
20	3/4	85	70	3/4" BSPP	32	32
25	1	97	77	1" BSPP	38	38
32	1.1/4	90	70	1.1/4" BSPP	50	50
40	1.1/2	97	72	1.1/2" BSPP	60	55
50	2	110	80	2" BSPP	70	70

Fig. 7C

Sphere cone nipple with hexagon swivel nut (fig.7) with welding adapter.

- Carbon steel / Stainless steel

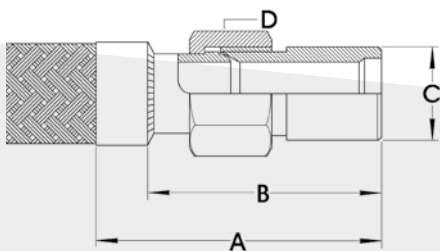

HOSE NOMINAL ID		DIMENSIONS IN MM				
(mm)	(inch)	A	B	C-ISO	C-ANSI	D
6	1/4	62	53	10,2 x 1,6		19
6	1/4	62	53	13,5 x 1,8	13,7 x 2,2	19
10	3/8	63	53	17,2 x 1,8	17,2 x 2,3	22
12	1/2	70	58	21,3 x 2,0	21,3 x 2,8	27
20	3/4	78	63	26,9 x 2,3	26,7 x 2,9	32
25	1	90	70	33,7 x 2,6	33,4 x 3,4	41
32	1.1/4	94	74	42,4 x 2,6	42,2 x 3,6	50
40	1.1/2	99	74	48,3 x 2,6	48,3 x 3,7	60
50	2	112	82	60,3 x 2,9	60,3 x 3,9	70

END CONNECTIONS

Fig. 7D

Spherical cone nipple with hexagon swivel nut (fig.7) with Hexagon adapter BSPT male (tapered thread).

- Carbon steel / Stainless steel

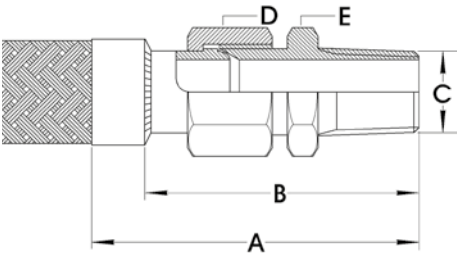

HOSE NOMINAL ID		DIMENSIONS IN MM				
(mm)	(inch)	A	B	C	D	E
6	1/4	67	58	1/4" BSPT	19	18
10	3/8	72	62	3/8" BSPT	22	23
12	1/2	83	71	1/2" BSPT	27	26
20	3/4	90	75	3/4" BSPT	32	33
25	1	109	89	1" BSPT	41	42
32	1.1/4	115	95	1.1/4" BSPT	50	52
40	1.1/2	117	97	1.1/2" BSPT	60	56
50	2	149	119	2" BSPT	70	70

Fig. 7E

Spherical cone nipple with hexagon swivel nut (fig.7) with hexagon adapter NPT male (tapered thread).

- Carbon steel / Stainless steel

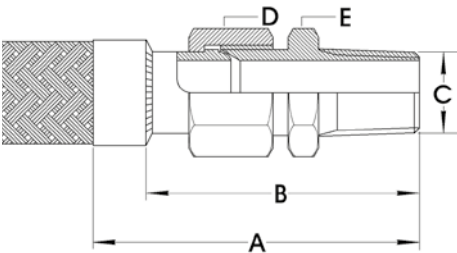

HOSE NOMINAL ID		DIMENSIONS IN MM				
(mm)	(inch)	A	B	C	D	E
6	1/4	67	58	1/4" NPT	19	18
10	3/8	72	62	3/8" NPT	22	23
12	1/2	83	71	1/2" NPT	27	26
20	3/4	90	75	3/4" NPT	32	33
25	1	109	89	1" NPT	41	42
32	1.1/4	115	95	1.1/4" NPT	50	52
40	1.1/2	117	97	1.1/2" NPT	60	56
50	2	149	119	2" NPT	70	70

Fig. 9B

Hexagon union BSPT male (tapered thread).

EN ISO 4144 - BW / cone seat / Male

- Stainless steel

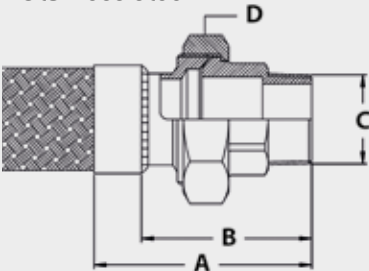

HOSE NOMINAL ID		DIMENSIONS IN MM				
(mm)	(inch)	A	B	C	D	E
6	1/4"	62	50	1/4" BSPT	30	18
10	3/8"	65	50	3/8" BSPT	35	23
12	1/2"	74	59	1/2" BSPT	42	26
20	3/4"	81	66	3/4" BSPT	47	33
25	1"	85	65	1" BSPT	53	42
32	1.1/4"	103	83	1.1/4" BSPT	71	52
40	1.1/2"	112	87	1.1/2" BSPT	78	56
50	2"	124	94	2" BSPT	92	70

END CONNECTIONS

Fig. 10B

Hexagon Union BSPP Female.
(parallel thread).
EN ISO 4144 - BW / cone seat / Female
- Stainless steel

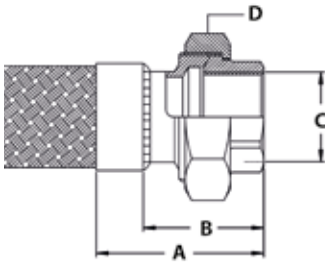

HOSE NOMINAL ID		DIMENSIONS IN MM			
(mm)	(inch)	A	B	C	D
6	1/4"	47,5	35,5	1/4" BSPP	30
10	3/8"	53	38	3/8" BSPP	35
12	1/2"	57	42	1/2" BSPP	42
20	3/4"	66	51	3/4" BSPP	47
25	1"	68	48	1" BSPP	53
32	1.1/4"	79	59	1.1/4" BSPP	71
40	1.1/2"	89	64	1.1/2" BSPP	78
50	2"	99	69	2" BSPP	92

Fig. 11

Hexagon union 3000 lbs NPT male
(tapered thread).
ANSI B16.11, forged to ASTM A182
- Carbon steel / Stainless steel

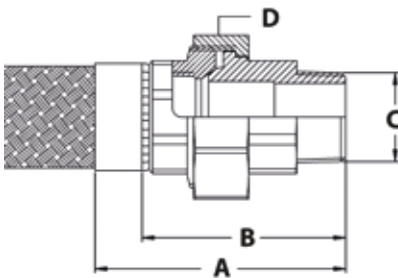

HOSE NOMINAL ID		DIMENSIONS IN MM			
(mm)	(inch)	A	B	C	D
6	1/4"	73	61	1/4" NPT	36
10	3/8"	84	69	3/8" NPT	41
12	1/2"	90	75	1/2" NPT	46
20	3/4"	100	80	3/4" NPT	56
25	1"	110	90	1" NPT	65
32	1.1/4"	118	98	1.1/4" NPT	80
40	1.1/2"	125	100	1.1/2" NPT	87
50	2"	150	120	2" NPT	100

Fig. 12

Hexagon Union 3000 lbs NPT female
(tapered thread).
ANSI B16.11, forged to ASTM A182
- Carbon steel / Stainless steel

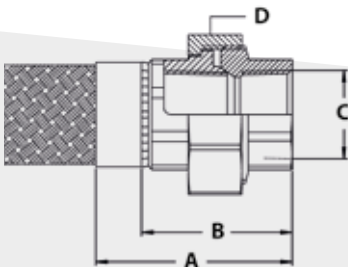

HOSE NOMINAL ID		DIMENSIONS IN MM			
(mm)	(inch)	A	B	C	D
6	1/4"	57	45	1/4" NPT	36
10	3/8"	66	51	3/8" NPT	41
12	1/2"	67	52	1/2" NPT	46
20	3/4"	72	57	3/4" NPT	56
25	1"	83	63	1" NPT	65
32	1.1/4"	86	66	1.1/4" NPT	80
40	1.1/2"	103	78	1.1/2" NPT	87
50	2"	121	91	2" NPT	100

END CONNECTIONS

Fig. 13

Fixed flange NW 06 to NW 100
EN1092-1 type 11
PN06 to PN40
- Carbon steel / Stainless steel

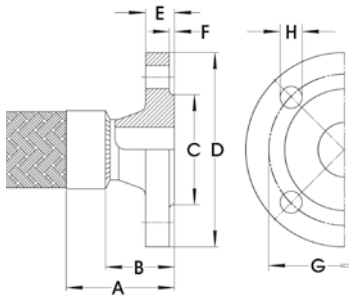

Fixed flange NW 125 to NW 250
EN1092-1 type 01
PN06 to PN40
- Carbon steel / Stainless steel

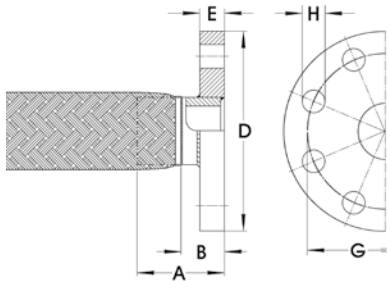

FIXED FLANGES ACCORDING TO EN 1092-1

PN 06 (DIN 2631*)

HOSE NOMINAL ID		DIMENSIONS IN MM								NUMBER OF HOLES
(mm)	(inch)	A	B	C	D	E	F	G	H	
10	3/8"	38	28	35	75	12	2	50	11	4
15	1/2"	42	30	40	80	12	2	55	11	4
20	3/4"	47	32	50	90	14	2	65	11	4
25	1"	55	35	60	100	14	2	75	11	4
32	1.1/4"	55	35	70	120	14	2	90	14	4
40	1.1/2"	63	38	80	130	14	3	100	14	4
50	2"	68	38	90	140	14	3	110	14	4
65	2.1/2"	68	38	110	160	14	3	130	14	4
80	3"	72	42	128	190	16	3	150	18	4
100	4"	75	45	148	210	16	3	170	18	4
125	5"	105	54	-	240	20	-	200	18	8
150	6"	105	54	-	265	20	-	225	18	8
200	8"	120	57	-	320	22	-	280	18	8
250	10"	120	57	-	375	24	-	335	18	12

PN 10 (DIN 2632*)

HOSE NOMINAL ID		DIMENSIONS IN MM								NUMBER OF HOLES
(mm)	(inch)	A	B	C	D	E	F	G	H	
10 to 150										
Use PN 40 dimensions										
50 to 150										
Use PN 16 dimensions										
200	8"	120	57		340	24		295	22	8
250	10"	120	57		395	26		350	22	12

PN 16 (DIN 2633*)

HOSE NOMINAL ID		DIMENSIONS IN MM								NUMBER OF HOLES
(mm)	(inch)	A	B	C	D	E	F	G	H	
10 to 40										
Use PN 40 dimensions										
50	2"	75	45	102	165	18	3	125	18	4
65	2.1/2"	75	45	122	185	18	3	145	18	4 / 8*
80	3"	80	50	138	200	20	3	160	18	8
100	4"	82	52	158	220	20	3	180	18	8
125	5"	105	54	-	250	22	-	210	18	8
150	6"	105	54	-	285	24	-	240	22	8
200	8"	120	57	-	340	26	-	295	22	12
250	10"	120	57	-	405	29	-	355	26	12

PN 25 (DIN 2634*)

HOSE NOMINAL ID		DIMENSIONS IN MM								NUMBER OF HOLES
(mm)	(inch)	A	B	C	D	E	F	G	H	
10 to 150										
Use PN 40 dimensions										
200	8"	120	57		360	32		310	26	12
250	10"	120	57		425	35		370	30	12

* The European standard EN 1092-1 is based on the old DIN- standard. However, there are a few small differences.

END CONNECTIONS

Fig. 13

Fixed flange NW 06 to NW 100
 EN1092-1 type 11
 PN06 to PN40
 - Carbon steel / Stainless steel

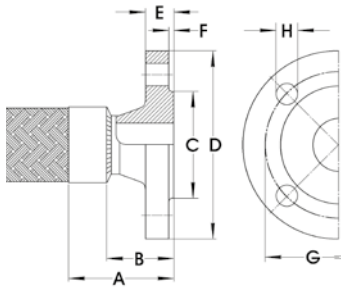

FIXED FLANGES ACCORDING TO EN 1092-1

PN 40 (DIN 2635*)

HOSE NOMINAL ID		DIMENSIONS IN MM								NUMBER OF HOLES
(mm)	(inch)	A	B	C	D	E	F	G	H	
10	3/8"	45	35	40	90	16	2	60	14	4
15	1/2"	50	38	45	95	16	2	65	14	4
20	3/4"	55	40	58	105	18	2	75	14	4
25	1"	60	40	68	115	18	2	85	14	4
32	1.1/4"	62	42	78	140	18	2	100	18	4
40	1.1/2"	70	45	88	150	18	3	110	18	4
50	2"	78	48	102	165	20	3	125	18	4
65	2.1/2"	82	52	122	185	22	3	145	18	8
80	3"	88	58	138	200	24	3	160	18	8
100	4"	95	65	162	235	24	3	190	22	8

Fixed flange NW 125 to NW 250
 EN1092-1 type 01
 PN06 to PN40
 - Carbon steel / Stainless steel

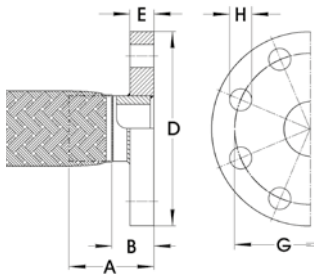

* The European standard EN 1092-1 is based on the old DIN- standard. However, there are a few small differences.

END CONNECTIONS

Fig. 14

Floating flange NW 06 to NW 100
EN1092-1 type 02/33 (thin plate collar)
PN10

- Carbon steel / Stainless steel

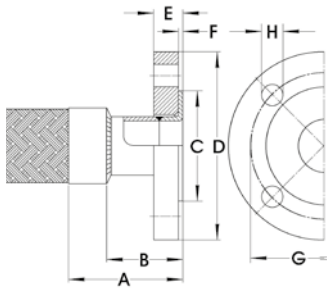

FIXED FLANGES ACCORDING TO EN 1092-1

PN 10 (DIN 2641 FORM G*)

HOSE NOMINAL ID		DIMENSIONS IN MM								NUMBER OF HOLES
(mm)	(inch)	A	B	C	D	E	F	G	H	
10	3/8"	62	52	40	90	14	2,5	60	14	4
15	1/2"	64	52	45	95	14	2,5	65	14	4
20	3/4"	67	52	58	105	16	3	75	14	4
25	1"	72	52	68	115	16	3	85	14	4
32	1.1/4"	72	52	78	140	18	3	100	18	4
40	1.1/2"	87	62	88	150	18	3	110	18	4
50	2"	92	62	102	165	20	4	125	18	4
65	2.1/2"	92	62	122	185	20	4	145	18	8
80	3"	98	68	138	200	20	4	160	18	8
100	4"	108	78	158	220	22	4	180	18	8
125	5"	177	126	188	250	22	4	210	18	8
150	6"	177	126	212	285	24	4	240	22	8
200	8"	203	139	268	340	24	4	295	22	8

* For pressure ratings PN16 and PN40 Type 37,35 and 34 collars are available upon request.

Floating flange NW 125 to NW 200
EN1092-1 type 02/33 (thin plate collar) PN10

- Carbon steel / Stainless steel

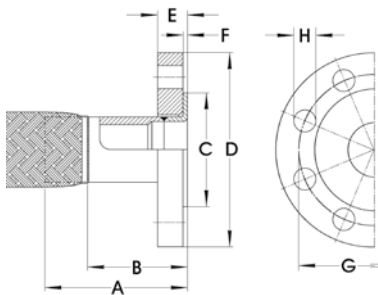

* The European standard EN 1092-1 is based on the old DIN- standard. However, there are a few small differences.

END CONNECTIONS

Fig. 14

Floating flange NW 06 to NW 100
EN1092-1 type 02/32 (thick collar)
PN06 to PN40

- Carbon steel / Stainless steel

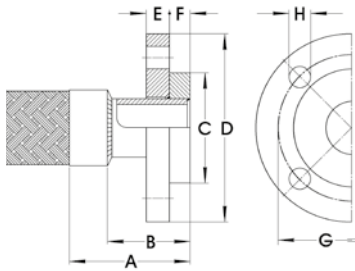

Floating flange NW 125 to NW 250
EN1092-1 type 02/32 (thick collar)
PN06 to PN40

- Carbon steel / Stainless steel

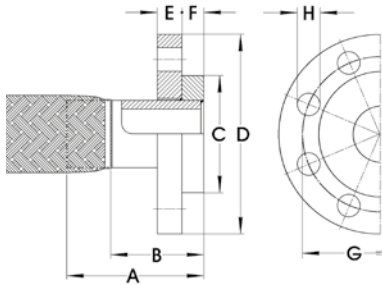

FIXED FLANGES ACCORDING TO EN 1092-1

PN 06 (DIN 2641*)

HOSE NOMINAL ID		DIMENSIONS IN MM								NUMBER OF HOLES
(mm)	(inch)	A	B	C	D	E	F	G	H	
10	3/8"	62	52	35	75	12	10	50	11	4
15	1/2"	64	52	40	80	12	10	55	11	4
20	3/4"	67	52	50	90	14	10	65	11	4
25	1"	72	52	60	100	14	10	75	11	4
32	1.1/4"	72	52	70	120	16	10	90	14	4
40	1.1/2"	87	62	80	130	16	10	100	14	4
50	2"	92	62	90	140	16	12	110	14	4
65	2.1/2"	92	62	110	160	16	12	130	14	4
80	3"	98	68	128	190	18	12	150	18	4
100	4"	108	78	148	210	18	14	170	18	4
125	5"	170	119	178	240	20	14	200	18	8
150	6"	170	119	202	265	20	14	225	18	8
200	8"	195	131	258	320	22	16	280	18	8
250	10"	200	136	312	375	24	18	335	18	12

PN 10 (DIN 2642*)

HOSE NOMINAL ID		DIMENSIONS IN MM								NUMBER OF HOLES
(mm)	(inch)	A	B	C	D	E	F	G	H	
10 to 40		Use PN 40 dimensions								
50 to 150		Use PN 16 dimensions								
200	8"	203	139	268	340	24	20	295	22	8
250	10"	207	143	320	395	26	22	350	22	12

PN 16 (DIN 2643*)

HOSE NOMINAL ID		DIMENSIONS IN MM								NUMBER OF HOLES
(mm)	(inch)	A	B	C	D	E	F	G	H	
10 to 40		Use PN 40 dimensions								
50	2"	92	62	102	165	20	16	125	18	4
65	2.1/2"	92	62	122	185	20	16	145	18	4 / 8*
80	3"	98	68	138	200	20	16	160	18	8
100	4"	108	78	158	220	22	18	180	18	8
125	5"	177	126	188	250	22	18	210	18	8
150	6"	177	126	212	285	24	20	240	22	8
200	8"	203	139	268	340	26	20	295	22	12
250	10"	207	143	320	405	29	22	355	26	12

* The European standard EN 1092-1 is based on the old DIN- standard. However, there are a few small differences.

END CONNECTIONS

Fig. 14

Floating flange NW 06 to NW 100
EN1092-1 type 02/32 (thick collar)
PN06 to PN40

- Carbon steel / Stainless steel

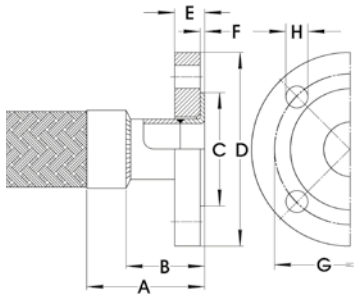

Floating flange NW 125 to NW 250
EN1092-1 type 02/32 (thick collar)
PN06 to PN40

- Carbon steel / Stainless steel

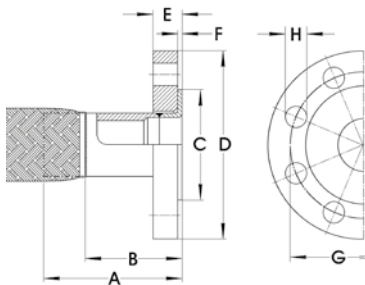

FIXED FLANGES ACCORDING TO EN 1092-1

PN 25 (DIN 2644*)

HOSE NOMINAL ID		DIMENSIONS IN MM								NUMBER OF HOLES
(mm)	(inch)	A	B	C	D	E	F	G	H	
10 to 150		Use PN 40 dimensions								
200	8"	213	149	278	360	32	26	310	26	12
250	10"	219	155	335	425	35	26	370	30	12

PN 40 (DIN 2635*)

HOSE NOMINAL ID		DIMENSIONS IN MM								NUMBER OF HOLES
(mm)	(inch)	A	B	C	D	E	F	G	H	
10	3/8"	62	52	40	90	14	12	60	14	4
15	1/2"	64	52	45	95	14	12	65	14	4
20	3/4"	67	52	58	105	16	14	75	14	4
25	1"	72	52	68	115	16	14	85	14	4
32	1.1/4"	72	52	78	140	18	14	100	18	4
40	1.1/2"	87	62	88	150	18	14	110	18	4
50	2"	92	62	102	165	20	16	125	18	4
65	2.1/2"	92	62	122	185	22	16	145	18	8
80	3"	98	68	138	200	24	18	160	18	8
100	4"	108	78	162	235	26	20	190	22	8

* The European standard EN 1092-1 is based on the old DIN- standard. However, there are a few small differences.

END CONNECTIONS

Fig. 13

Fixed flange 1/2" to 4"
ANSI welding neck / RF
Pressure class 150 lbs, 300 lbs
Carbon steel / Stainless steel

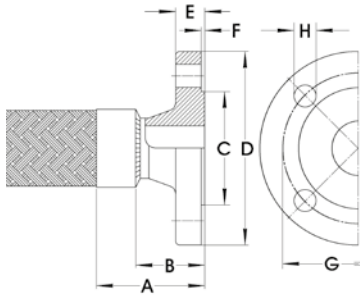

FIXED FLANGES ACCORDING TO ANSI / ASME B16.5

ANSI 150 lbs.

HOSE NOMINAL ID		DIMENSIONS IN MM								NUMBER OF HOLES
(mm)	(inch)	A	B	C	D	E	F	G	H	
12	1/2"	60	48	35,0	89,0	11,2	1,6	60,5	16,0	4
20	3/4"	67	52	43,0	98,5	12,7	1,6	70,0	16,0	4
25	1"	76	56	51,0	108,0	14,2	1,6	79,5	16,0	4
32	1.1/4"	77	57	63,5	117,5	15,7	1,6	89,0	16,0	4
40	1.1/2"	87	62	73,0	127,0	17,5	1,6	98,5	16,0	4
50	2"	94	64	92,0	152,5	19,1	1,6	120,5	19,0	4
65	2.1/2"	100	70	105,0	178,0	22,4	1,6	139,5	19,0	4
75	3"	100	70	127,0	190,5	23,9	1,6	152,5	19,0	4
100	4"	106	76	157,0	228,5	23,9	1,6	190,5	19,0	8
125	5"	127	77	185,5	254,0	23,9	1,6	216,0	22,0	8
150	6"	130	80	216,0	279,5	25,4	1,6	241,5	22,0	8
200	8"	150	90	270,0	343,0	28,4	1,6	298,5	22,0	8
250	10"	156	96	324,0	406,5	30,2	1,6	362,0	25,5	12

Fixed flange 5" to 10"
ANSI Slip-on / RF
Pressure class 150 lbs, 300 lbs
Carbon steel / Stainless steel

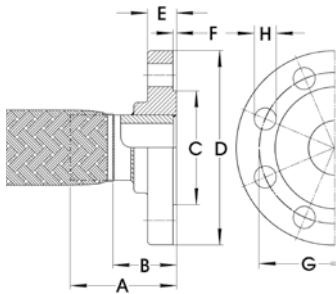

ANSI 300 lbs.

HOSE NOMINAL ID		DIMENSIONS IN MM								NUMBER OF HOLES
(mm)	(inch)	A	B	C	D	E	F	G	H	
12	1/2"	64	52	35,0	95,0	14,2	1,6	66,5	16,0	4
20	3/4"	72	57	43,0	117,5	15,7	1,6	82,5	19,0	4
25	1"	82	62	51,0	124,0	17,5	1,6	89,0	19,0	4
32	1.1/4"	85	65	63,5	133,5	19,0	1,6	98,5	19,0	4
40	1.1/2"	93	68	73,0	155,5	20,6	1,6	114,5	22,0	4
50	2"	100	70	92,0	165,0	22,3	1,6	127,0	19,0	8
65	2.1/2"	106	76	105,0	190,5	25,4	1,6	149,0	22,0	8
75	3"	109	79	127,0	209,5	28,4	1,6	168,5	22,0	8
100	4"	116	86	157,0	254,0	31,7	1,6	200,0	22,0	8
125	5"	127	77	185,5	279,5	35,0	1,6	235,0	22,0	8
150	6"	130	80	216,0	317,5	36,5	1,6	270,0	22,0	12
200	8"	150	90	270,0	381,0	41,1	1,6	330,0	25,5	12
250	10"	156	96	324,0	444,5	47,7	1,6	387,5	28,5	16

END CONNECTIONS

Fig. 14

Floating flange 1/2" to 4"
ANSI lap joint with stub-end.
Pressure class 150 lbs, 300 lbs
Carbon steel / Stainless steel

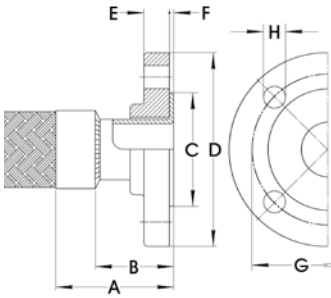

FLOATING FLANGES ACCORDING TO ANSI / ASME B16.5

ANSI 150 lbs.

HOSE NOMINAL ID		DIMENSIONS IN MM								NUMBER OF HOLES
(mm)	(inch)	A	B	C	D	E	F	G	H	
12	1/2"	64	51	35,0	89,0	9,6	2,11	60,5	16,0	4
20	3/4"	67	51	43,0	98,5	11,1	2,11	70,0	16,0	4
25	1"	72	51	51,0	108,0	12,6	2,77	79,5	16,0	4
32	1.1/4"	72	51	63,5	117,5	14,1	2,77	89,0	16,0	4
40	1.1/2"	77	51	73,0	127,0	15,9	2,77	98,5	16,0	4
50	2"	94	64	92,0	152,5	17,5	2,77	120,5	19,0	4
65	2.1/2"	94	64	105,0	178,0	20,8	3,05	139,5	19,0	4
75	3"	98	64	127,0	190,5	22,3	3,05	152,5	19,0	4
100	4"	108	76	157,0	228,5	22,3	3,05	190,5	19,0	8
125	5"	200	150	185,5	254,0	22,3	3,40	216,0	22,0	8
150	6"	200	150	216,0	279,5	23,8	3,40	241,5	22,0	8
200	8"	235	175	270,0	343,0	26,8	3,80	298,5	22,0	8
250	10"	270	210	324,0	406,5	28,6	4,20	362,0	25,5	12

Floating flange 5" to 10"
ANSI lap joint with stub-end.
Pressure class 150 lbs, 300 lbs
Carbon steel / Stainless steel

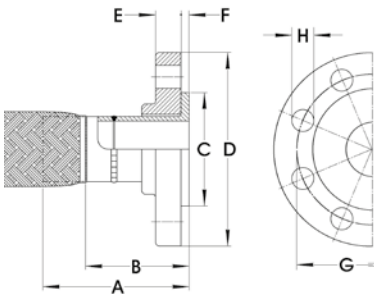

ANSI 300 lbs.

HOSE NOMINAL ID		DIMENSIONS IN MM								NUMBER OF HOLES
(mm)	(inch)	A	B	C	D	E	F	G	H	
12	1/2"	64	51	35,0	95,0	12,6	2,11	66,5	16,0	4
20	3/4"	67	51	43,0	117,5	14,1	2,11	82,5	19,0	4
25	1"	72	51	51,0	124,0	15,9	2,77	89,0	19,0	4
32	1.1/4"	72	51	63,5	133,5	17,4	2,77	98,5	19,0	4
40	1.1/2"	87	51	73,0	155,5	19,0	2,77	114,5	22,0	4
50	2"	92	64	92,0	165,0	20,7	2,77	127,0	19,0	8
65	2.1/2"	92	64	105,0	190,5	23,8	3,05	149,0	22,0	8
75	3"	98	64	127,0	209,5	26,8	3,05	168,5	22,0	8
100	4"	108	76	157,0	254,0	30,1	3,05	200,0	22,0	8
125	5"	200	150	185,5	279,5	33,4	3,40	235,0	22,0	8
150	6"	200	150	216,0	317,5	34,9	3,40	270,0	22,0	12
200	8"	235	175	270,0	381,0	39,5	3,80	330,0	25,5	12
250	10"	270	210	324,0	444,5	46,1	4,20	387,5	28,5	16

Anaflex® corrugated hose:

QUICK AND PERFECT SOLUTION FOR EVERY HVAC INSTALLATION

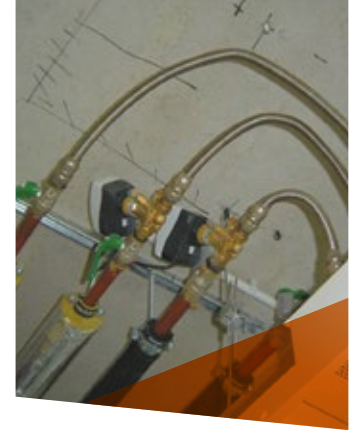

ANAFLEX® from Anamet Europe B.V. is the perfect flexible solution for HVAC installations. The ideal solution for a great number of applications. The ANAFLEX® system has been designed as a self-mounting flexible hose system for heating, steam-tracing, cooling-ceilings, watersupply, boiler-connection, machine-fluid-connection and solar-panel-connection applications. The flexible ANAFLEX® corrugated hose is made of high quality stainless steel (AISI-316L), does not age and is diffusion-tight. ANAFLEX® solves the problem of rubber and plastic hoses, which due to oxygen-diffusion and ageing can damage the installation. The flexible stainless steel hose is easy to handle and easy to cut to the desired length, which saves installation time.

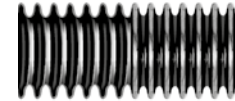

Standard corrugation

Material & Construction:

Construction: Flexible parallel corrugated hose, made of thin wall stainless steel AISI-316L

Temperature range: 0 °C tot +110 °C (for higher temperatures till +250 °C please consult Anamet Europe B.V.).

Colour: Metal.

Product advantages:

- No oxygen diffusion, prevents damage and does not block the installation.

- Does not kink.
- Durable and does not age.
- Is corrosion resistant.

Mounting advantages:

- You decide the length on the spot.
- Quick and efficient mounting.
- Smooth installation.
- Very long life time.

ANAFLEX® Size DN	DIAMETRE		WORKING-PRESSURE (Bar)	BENDING-RADIUS Static (mm) *	STANDARD CARTON		SMALL CARTON		REEL		WEIGHT (Kg/m)
	Inside (mm)	Outside (mm)			Metre	Article No.	Metre	Article No.	Metre	Article No.	
DN 12	12,2	16,7	12	45	30	465.012.1	10	465.012.3	120	465.012.5	0,12
DN 16	16,2	21,5	10	60	30	465.016.1	10	465.016.3	90	465.016.5	0,20
DN 20	20,3	26,7	8	70	30	465.020.1	10	465.020.3	60	465.020.5	0,28
DN 25	25,4	32,3	6	100	30	465.025.1	10	465.025.3	-	-	0,39

* For dynamic applications, please consult your Anamet representative.

The ANAFLEX® stainless steel hoses can be used in combination with the unique ANAFLEX®-CLICK fittings, as mentioned on the next page.

This combination gives you many advantages:

- You can install the fittings yourself.
- Quick and efficient working method.
- Significant installation time reduction.
- Smooth and perfect result.



Anaflex®	12	16	20	25
Male BSPT	3/8"-1/2"	1/2"-3/4"	3/4"-1"	1"
Female BSPP	3/8"-1/2"	1/2"-3/4"	3/4"-1"	1"
Pipe compression	-	15-18 mm	18-22 mm	-

Anaflex® -click fittings:

NICKEL PLATED BRASS FITTINGS WITH UNIQUE CLICK-SYSTEM

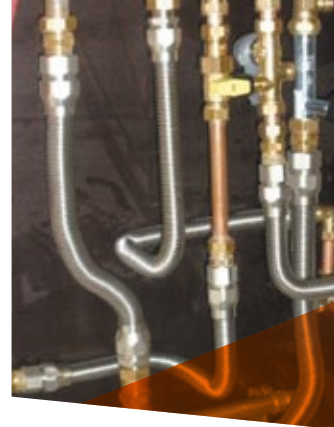

For the stainless steel ANAFLEX® corrugated hose an unique mounting fitting has been developed. The major advantage of the ANAFLEX® -CLICK fitting is the quick-mounting directly on the hose. After turning the backnut (2 till 3 full turns) a tensile strong and liquid-tight connection is made. The nickel plated brass fittings are suitable for cold and hot water as well as steam.

Material & Construction:

Construction: Nickel plated brass fitting, consisting of 6 parts (body, counter nut, retaining ring and filler ring are nickel plated brass, internal sealing sleeve is from PTFE and the internal flat seal is from silicone rubber).

Special approvals: Click system tested and approved by the "Institut für Solartechnik SPF" (Switzerland).

Temperature range: 0 °C till +110 °C (for higher temperatures please consult Anamet Europe B.V.).

Colour: metal.

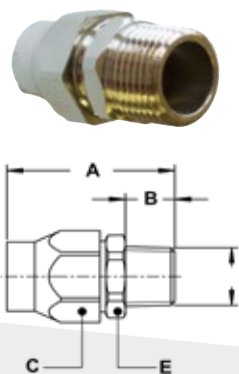

Figure C3, nickel plated brass click fitting, male, BSPT

THREAD	ANAFLEX	ID HOSE	DIMENSIONS IN MM					STANDARD	ARTICLE	WEIGHT
size	Size (DN)	(MM)	A	B	C	D	E	PACKAGE	NUMBER	(Kg/100)
3/8" BSPT	DN 12	12,2	49	14	24	-	22	10	400.010.3	6,1
1/2" BSPT	DN 12	12,2	50	15	24	-	22	10	400.012.3	6,3
1/2" BSPT	DN 16	16,2	58	17	29	-	27	10	400.016.3	9,7
3/4" BSPT	DN 16	16,2	59	17	29	-	27	10	400.018.3	10,5
3/4" BSPT	DN 20	20,3	62	17	36	-	34	10	400.020.3	16,0
1" BSPT	DN 20	20,3	66	18	36	-	34	10	400.022.3	18,3
1" BSPT	DN 25	24,0	63	18	42	-	40	5	400.025.3	22,8

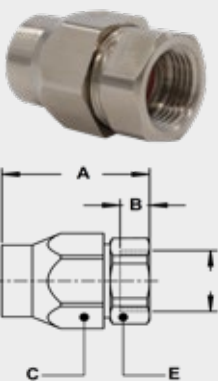

Figure C5, nickel plated brass click fitting, female, BSPP, flat seat

THREAD	ANAFLEX	ID HOSE	DIMENSIONS IN MM					STANDARD	ARTICLE	WEIGHT
size	Size (DN)	(MM)	A	B	C	D	E	PACKAGE	NUMBER	(Kg/100)
1/2" BSPP	-	DN 16	48	9	29	-	27	10	400.010.5	9,5
3/4" BSPP	-	DN 20	51	10	36	-	34	10	400.020.5	715,0

ANAFLEX® -CLICK FITTINGS

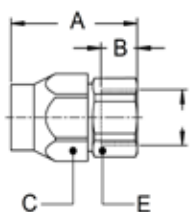

Figure C6, nickel plated brass click fitting, female, BSPP

THREAD	ANAFLEX	ID HOSE	DIMENSIONS IN MM					STANDARD	ARTICLE	WEIGHT
size	Size (DN)	(MM)	A	B	C	D	E	PACKAGE	NUMBER	(Kg/100)
3/8" BSPP	DN 12	12,2	45	13	24	-	22	10	400.010.6	6,5
1/2" BSPP	DN 12	12,2	48	15	24	-	27	10	400.012.6	7,8
1/2" BSPP	DN 16	16,2	54	15	29	-	27	10	400.016.6	9,9
3/4" BSPP	DN 16	16,2	55	17	29	-	32	10	400.018.6	11,8
3/4" BSPP	DN 20	20,3	58	17	36	-	34	10	400.020.6	16,6
1" BSPP	DN 20	20,3	62	20	36	-	41	10	400.022.6	22,1
1" BSPP	DN 25	24,0	65	20	42	-	40	5	400.025.6	22,8

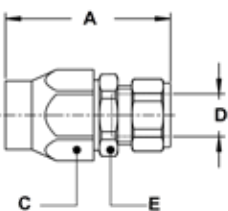

Figure C8, nickel plated brass click fitting, pipe compression.

PIPE	ANAFLEX	ID HOSE	DIMENSIONS IN MM					STANDARD	ARTICLE	WEIGHT
diameter	Size (DN)	(MM)	A	B	C	D	E	PACKAGE	NUMBER	(Kg/100)
Ø 15 mm	DN 16	16,2	60	-	29	15	27	10	400.015.8	9,9
Ø 18 mm	DN 16	16,2	61	-	29	18	32	10	400.018.8	11,8
Ø 18 mm	DN 20	20,3	66	-	36	18	34	10	400.020.8	16,6
Ø 22 mm	DN 20	20,3	67	-	36	22	41	10	400.022.8	22,1

Anaconda Multiflex hose

TYPE UIG



VERY ROBUST AND EXTREMELY FLEXIBLE

Anaconda Multiflex type UIG is a flexible, fully interlocked, galvanized steel hose that has excellent tensile, torsional and crush strength. It is an excellent choice in demanding applications requiring a high degree of mechanical and thermal protection against hot metal swarf and chips and other potentially damaging materials. Typical applications include: robots in steel and automotive plants, foundries, die casting and metalworking machines.

Material & Construction:

Construction: Galvanised steel core, fully inter locked.

Temperature: -55 °C till +300 °C.

Colour: Metal coloured.

Classification according NEN-EN-IEC 61386:

Compression resistance: Class 5, Very Heavy (4000 N).

Impact resistance: Class 4, Heavy (6 J).

Tensile strength: Class 4, Heavy (1000 N).

Protection class: IP 40.



Inter locked

UIG	DIAMETRE		BENDING RADIUS (CL)		STANDARD CARTON		SMALL CARTON		REEL		WEIGHT (kg/m)
	Size (inch)	Inside (mm)	Outside (mm)	Static (mm)	Dynamic (mm)	Metre	Article No.	Metre	Article No.	Metre	
5/16"	9,5	12,5	50	60	30	515.010.0	-	-	-	-	0,12
3/8"	13	16	65	80	30	515.012.0	-	-	-	-	0,2
1/2"	17	21	75	100	30	515.016.0	-	-	-	-	0,3
3/4"	22	26	90	125	30	515.022.0	-	-	-	-	0,4
1"	26	30	120	160	30	515.025.0	-	-	-	-	0,47
1 1/4"	34	39	175	220	30	515.034.0	-	-	-	-	0,67
1 1/2"	40,3	44,4	230	280	15	515.040.0	-	-	-	-	0,73
2"	51,6	55,7	285	340	15	515.050.0	-	-	-	-	1,6
2 1/2"	63,3	67,4	350	400	7,5	515.063.0	-	-	-	-	1,9
3"	78,4	84,2	430	600	7,5	515.075.0	-	-	-	-	2,4
4"	102,1	108	490	700	7,5	515.099.0	-	-	-	-	3,1

* On demand the UIG metal hose in the sizes 1 1/2" and 2" can be ordered in production reels having variable lengths, in this case the codes change as following:
1 1/2" = 109.040.0 and 2" = 109.050.0.

Anaconda Multiflex hose

TYPE UI



VERY ROBUST, EXTREMELY FLEXIBLE AND CORROSION RESISTANT

Anaconda Multiflex type UI is the stainless steel version of type UIG. Extremely flexible and robust, this fully interlocked, stainless steel AISI-304 in addition to having excellent tensile, torsional and crush strength, it is also high corrosion and oxidation resistant. It is an optimal choice for protection of cables in dynamic motions. Typical applications include: robots in steel and automotive plants, foundries, die casting and metalworking machines, closed circuit TV (CCTV) security recording systems and video cameras, passenger information systems, door locking systems and rail sector.

Material & Construction:

Construction: Stainless steel core (AISI-304), fully inter locked.

Special flame properties: Because the UI hose has no cover the flame properties

according the following standards are valid:

- EN 45545-2 (2013):
R22 (interior equipment): class HL1, HL2 and HL3.
R23 (exterior equipment): class HL1, HL2 and HL3.

- BS 6853 (1999):
Tabel 7 (Interior): Category 1a, 1b and II vehicle.
Tabel 8 (Exterior): Category 1a, 1b and II vehicle.
- London Underground LUL 1-085 (2011):
Tabel 3: Extensive and grouped usage.
Tabel 4: Limited and dispersed usage.

Temperature: -100 °C till +600 °C.

Colour: Metal coloured.

Classification according to NEN-EN-IEC 61386:

Compression resistance: Class 5, Very Heavy (4000 N).

Impact resistance: Class 4, Heavy (6 J).

Tensile strength: Class 4, Heavy (1000 N).

Protection class: IP 40.

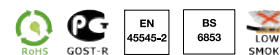

Inter locked

UI	DIAMETRE		BENDING RADIUS (CL)		STANDARD CARTON		SMALL CARTON		REEL		WEIGHT (kg/m)
	Size (inch)	Inside (mm)	Outside (mm)	Static (mm)	Dynamic (mm)	Metre	Article No.	Metre	Article No.	Metre	
5/16"	9,5	12,5	50	60	30	512.010.0	-	-	-	-	0,17
3/8"	13	16	65	80	30	512.012.0	-	-	-	-	0,27
1/2"	17	21	75	100	30	512.016.0	-	-	-	-	0,34
3/4"	22	26	90	125	30	512.022.0	-	-	-	-	0,37
1"	26	30	120	160	30	512.025.0	-	-	-	-	0,53
1 1/4"	34	39	175	220	30	512.034.0	-	-	-	-	0,73
1 1/2"	40,3	44,4	230	280	15	512.040.0	-	-	-	-	0,87
2"	51,6	55,7	285	340	15	512.050.0	-	-	-	-	1,34

Hiprojacket Aero red



BRAIDED SLEEVING, SOLID CONSTRUCTED ACC. SAE AS1072, SUPERIOR SHORT TERM FLAME PROTECTION

The ultimate heatprotection for cables and hoses. This solid braided glassfiber sleeving, with thick silicone cover, is constructed according to the Aerospace Standard SAE AS1072 and allows qualified hose assemblies to pass the AS1055 testing. This Hiprojacket offers superior short term flame protection and excellent temperature reduction. In the field of cable protection, a complete program of Hiprojacket fittings is available for easy installation. Resistant to hydraulic fluids, lubricating oils and fuels, Hiprojacket protects against molten splash, occasional flames, heat radiation, energy loss in piping and hoses; also protects employees from burns. Hiprojacket is typically used in the Aerospace-industry, steelworks, glass and ceramics industry, as well as in the machine- and apparatus-building.

Material & Construction:

Construction: Braided sleeving from E-glass yarns, solid constructed according Aerospace Standard SAE AS1072 type 2.

Cover specifications: Iron-oxide silicon rubber. Excellent oil resistant, halogen free, superior short term flame protection, excellent temperature reduction and withstands molten splash.

Special approvals:

- Highly flameretardant acc. DIN 5510-2: S4 / SR2 / ST2.
- Flameretardant acc. UNI CEI 11170-3.
- NF EN ISO 11925-2 (15 and 30 sec.).

- EN 45545-2; R22 and R23 HL1 / HL2 / HL3, (CIT_{nlp} = 0,02 / D_s max = 70 and LOI = 40,1).

- Allows qualified hose assemblies to pass the SAE AS1055 testing.

Temperature: -55 °C till +260 °C continuous.

- Under flame till +800 °C for approx. 20 minutes.
- Radiation heat till +800 °C for approx. 20 minutes.
- Molten metal splash till +1640 °C for 15 - 30 seconds.

Colour: Red, other colours available on demand.



HIPROJACKET AERO			DIAMETRE		STANDARD CARTON		SMALL CARTON*		RANDOM LENGTH		WEIGHT
Size (mm)	Size (inch)	Type	Inside (mm)	Outside (mm)	Metre	Article No. red	Metre	Article No. red	Metre	Article No. red	(kg/m)
6	1/4"	HJ-04	6	11	30	336.006.3	15	336.006.1	1	336.006.0	0,12
10	3/8"	HJ-06	10	15	30	336.010.3	15	336.010.1	1	336.010.0	0,16
13	1/2"	HJ-08	13	18	30	336.013.3	15	336.013.1	1	336.013.0	0,19
16	5/8"	HJ-10	16	22	30	336.016.3	15	336.016.1	1	336.016.0	0,21
19	3/4"	HJ-12	19	25	30	336.019.3	15	336.019.1	1	336.019.0	0,24
22	7/8"	HJ-14	22	28	30	336.022.3	15	336.022.1	1	336.022.0	0,28
25	1"	HJ-16	25	31	30	336.025.3	15	336.025.1	1	336.025.0	0,33
29	1.1/8"	HJ-18	29	35	30	336.029.3	15	336.029.1	1	336.029.0	0,35
32	1.1/4"	HJ-20	32	38	30	336.032.3	15	336.032.1	1	336.032.0	0,39
35	1.3/8"	HJ-22	35	41	30	336.035.3	15	336.035.1	1	336.035.0	0,45
38	1.1/2"	HJ-24	38	44	30	336.038.3	15	336.038.1	1	336.038.0	0,48
41	1.5/8"	HJ-26	41	47	30	336.041.3	15	336.041.1	1	336.041.0	0,52
44	1.3/4"	HJ-28	44	50	30	336.044.3	15	336.044.1	1	336.044.0	0,64
51	2"	HJ-32	51	57	30	336.051.3	15	336.051.1	1	336.051.0	0,67
57	2.1/4"	HJ-36	57	63	30	336.057.3	15	336.057.1	1	336.057.0	0,74
64	2.1/2"	HJ-40	64	70	30	336.064.3	15	336.064.1	1	336.064.0	0,75
70	2.3/4"	HJ-44	70	76	30	336.070.3	15	336.070.1	1	336.070.0	0,88
76	3"	HJ-48	76	82	30	336.076.3	15	336.076.1	1	336.076.0	1,03
83	3.1/4"	HJ-52	83	89	30	336.083.3	15	336.083.1	1	336.083.0	1,13
89	3.1/2"	HJ-56	89	95	30	336.089.3	15	336.089.1	1	336.089.0	1,18
95	3.3/4"	HJ-60	95	101	30	336.095.3	15	336.095.1	1	336.095.0	1,34
102	4"	HJ-64	102	108	30	336.102.3	15	336.102.1	1	336.102.0	1,41

* In the 15 meter packaging it is possible that 2 lengths (totally 15 meter) are packed (minimum shortest length 4,5 meter).

Hiprojacket Industrial red



KNITTED SLEEVING, GOOD SHORT TERM FLAME PROTECTION

The industrial alternative for less demanding situations. This Industrial Grade has a more open construction of glass fibre, but due to the thick silicon cover still offers good short term flame protection and temperature reduction. Resistant to hydraulic fluids, lubricating oils and fuels, Hiprojacket Industrial protects against molten splash, occasional flames, heat radiation, energy loss in piping and hoses; also protects employees from burns. Hiprojacket Industrial is frequently used to protect cables and industrial rubber or metal hoses in the glass, ceramics and steel industry, as well as in the machine- and apparatus-building.

Material & Construction:

Construction: Knitted sleeving from E-glass yarns.

Cover specifications: Iron-oxide silicon rubber, excellent oil resistant, halogen free, good short term flame protection, good temperature reduction and withstands molten splash.

Temperature: -55 °C till +260 °C continuous.

- Under flame till +800 °C for approx. 20 minutes.
- Radiation heat till +800 °C for approx. 20 minutes.
- Molten metal splash till +1640 °C for 15 - 30 seconds.

Colour: Red, other colours available on demand.



HIPROJACKET INDUSTRIAL			DIAMETRE		STANDARD CARTON		SMALL CARTON		RANDOM LENGTH		WEIGHT
Size (mm)	Size (inch)	Type	Inside (mm)	Outside (mm)	Metre	Article No. red	Metre	Article No. red	Metre	Article No. red	(kg/m)
6	1/4"	HJ-I-04	6	11	30	336.806.3	-	-	-	-	0,11
10	3/8"	HJ-I-06	10	15	30	336.810.3	-	-	-	-	0,14
13	1/2"	HJ-I-08	13	18	30	336.813.3	-	-	-	-	0,17
16	5/8"	HJ-I-10	16	22	30	336.816.3	-	-	-	-	0,22
19	3/4"	HJ-I-12	19	25	30	336.819.3	-	-	-	-	0,25
22	7/8"	HJ-I-14	22	28	30	336.822.3	-	-	-	-	0,26
25	1"	HJ-I-16	25	31	30	336.825.3	-	-	-	-	0,3
29	1.1/8"	HJ-I-18	29	35	30	336.829.3	-	-	-	-	0,34
32	1.1/4"	HJ-I-20	32	38	30	336.832.3	-	-	-	-	0,36
35	1.3/8"	HJ-I-22	35	41	30	336.835.3	-	-	-	-	0,48
38	1.1/2"	HJ-I-24	38	44	30	336.838.3	-	-	-	-	0,53
41	1.5/8"	HJ-I-26	41	47	30	336.841.3	-	-	-	-	0,53
44	1.3/4"	HJ-I-28	44	50	30	336.844.3	-	-	-	-	0,55
51	2"	HJ-I-32	51	57	30	336.851.3	-	-	-	-	0,62
57	2.1/4"	HJ-I-36	57	63	30	336.857.3	-	-	-	-	0,71
64	2.1/2"	HJ-I-40	64	70	30	336.864.3	-	-	-	-	0,73
70	2.3/4"	HJ-I-44	70	76	30	336.870.3	-	-	-	-	0,82
76	3"	HJ-I-48	76	82	30	336.876.3	-	-	-	-	0,93
83	3.1/4"	HJ-I-52	83	89	30	336.883.3	-	-	-	-	1,14
89	3.1/2"	HJ-I-56	89	95	30	336.889.3	-	-	-	-	1,15
95	3.3/4"	HJ-I-60	95	100	30	336.895.3	-	-	-	-	1,17
102	4"	HJ-I-64	102	108	30	336.897.3	-	-	-	-	1,22
114	4.1/2"	HJ-I-72	114	120	30	336.898.3	15	336.898.1	-	-	1,65
127	5"	HJ-I-80	127	133	30	336.899.3	15	336.899.1	-	-	1,71

Hiprotape red



TAPE FROM WOVEN FIBERGLASS YARNS, WITH RED IRON-OXIDE SILICON RUBBER

Hiprotape provides the same heat protection as Hiprojacket Industrial Grade, in the form of a band which can be wrapped around already installed cables, hoses and valves. Resistant to hydraulic fluids, lubricating oils and fuels, Hiprotape protects against molten splash, occasional flames, energy loss in piping and hoses; also protects employees from burns; allows "bundling" of wires, hoses and cables. Hiprotape is applicable to larger diameters pipe and allows installation in situations where it is impractical or impossible to disassemble existing cable and hose assemblies. Typically used in the glass, ceramics and steel industry, as well as in the machine- and apparatus-building.

Material & Construction:

Construction: Woven tape from E-glass yarns.

Cover specifications: Iron-oxide silicon rubber, excellent oil resistant, halogen free, good short term flame protection, good temperature reduction and withstands molten splash.

Temperature: -55 °C till +260 °C continuous.

- Under flame till +800 °C for approx. 20 minutes.
- Radiation heat till +800 °C for approx. 20 minutes.
- Molten metal splash till +1640 °C for 15 - 30 seconds.

Colour: Red.



HIPROTAPE			DIAMETRE		STANDARD CARTON		SMALL CARTON		RANDOM LENGTH		WEIGHT
Size (mm)	Size (inch)	Type	Width (mm)	Thickness (mm)	Metre	Article No. red	Metre	Article No. red	Metre	Article No. red	(kg/m)
25	1"	HT-1	25	3	30	337.025.3	15	337.025.1	-	-	0,07
51	2"	HT-2	51	3	30	337.050.3	15	337.050.1	-	-	0,18
76	3"	HT-3	76	3	30	337.076.3	15	337.076.1	-	-	0,26
102	4"	HT-4	102	3	30	337.100.3	15	337.100.1	-	-	0,4
127	5"	HT-5	127	3	30	337.127.3	15	337.127.1	-	-	0,47

Important points when installing hose assemblies

Axial load

Axial compression may lead to squirm of the corrugated hose. Axial tension lowers the pressure capacity of braided hose.

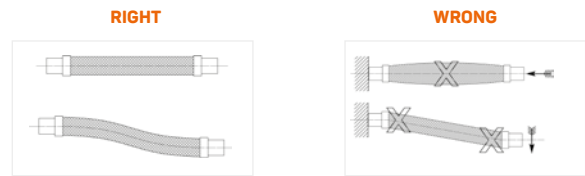

Bending

Install a hose in its most natural loop. Overbending lowers the pressure capacity and the cycle life

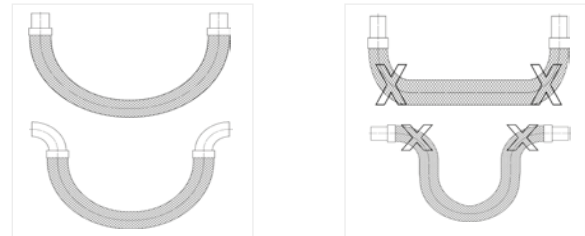

Weight

The weight of the hose and the medium must be supported adequately.

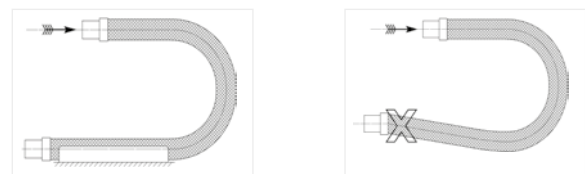

Torsion

Torsion must be avoided. Torsion occurs when the movements are not in the same plane as the fittings.

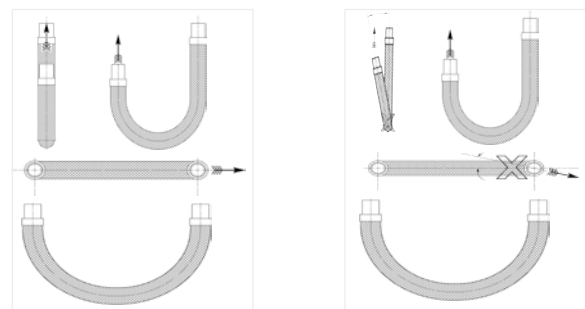

INSTRUCTIONS FOR SELECTING, INSTALLATING AND MOUNTING

The life time of metal hoses will increase when the following instructions are implemented:

1. Select the right fittings

Whenever possible select at least one swivel fitting or a floating flange. This avoids torsion problems during installation.

2. Do not overbend the hose (check technical data)

Avoid overbending, specially close to the fittings. Install the hose in its most natural position, free of kinks and sharp bends.

3. Do not torque a corrugated metal hose

Torsion can have dramatic consequences on the life of a corrugated metal hose. Torsion occurs when the movements are not in the same plane as the fittings. Use two keys when fixing swivel nuts. Note: Stripwound hose can absorb some torsion.

4. Avoid scratching over rough surfaces

The braiding is the essential part of a hose assembly to withstand the internal pressure. A damaged braid diminishes the pressure capacity of the assembly and is detrimental to its function.

5. Avoid exposure to weld or grinding splatters

Weld or grind splatters may lead to corrosion of the stainless steel parts. Use a heat proof shield (no plastic!) during welding or grinding in the proximity of metal hoses.

Engineering data

DETERMINING MINIMUM OVERALL LENGTH FOR INTERMITTENT FLEXURE

From the "minimum c/l bend radius for flexing bend" column in the hose specifications, obtain the proper bend radius for the type and size of hose chosen. Use the formulae below to calculate the length "A" of the exposed hose required. Determine the overall length of fittings from fitting specification pages and add to the exposed length of hose "A" to arrive at the assembly overall length. Distance between end connections should be such that there is no stress on the hose in the extreme offset position.

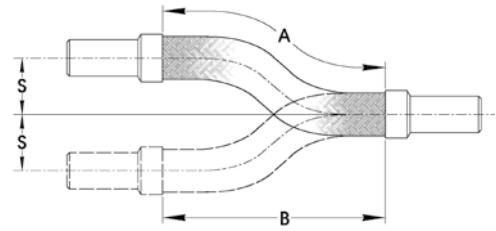

FOR INTERMITTENT FLEXURE

Use formulae and table for "K" below to determine the required hose length "A".

Formula $A = 2,8\sqrt{R_n \times 2S}$
 $B = K \times A$

* When $S \leq 0,5R_n$, otherwise another installation is required.

In order to find the overall length, add the length of the fittings to the calculated length "A".

Example

Hose nominal I.D. 32 mm.
 Type BW656-1S, min. c/l bend radius for flexing bend $R_n = 230$ mm from table.
 Desired movement $S = 80$ mm, $0,5R_n = 0,5 \times 230 = 115 \rightarrow S(=80) \leq 115 \rightarrow$ is allowed.

Calculation

$A = 2,8\sqrt{230 \times 2 \times 80} = 537$ mm
 $A/S = 537 / 80 = 6,71$
 $K = 0,988$ (see table "K")
 $B = 0,988 \times 537 = 531$ mm

FOR NON-MOVING OFFSET INSTALLATIONS

Use formulae and table for "K" below to determine the required hose length "A".

Formula $A = 2\sqrt{R_p \times 2S}$
 $B = K \times A$

* When $S \leq 1,5R_p$, otherwise another installation is required.

In order to find the overall length, add the length of the fittings to the calculated length "A".

Example

Hose nominal I.D. 50 mm.
 Type BW856 -1H, min. c/l bend radius for permanent bend $R_p = 140$ mm from table.
 Desired movement $S = 120$ mm, $1,5R_p = 1,5 \times 140 = 210 \rightarrow S(=120) \leq 210 \rightarrow$ is allowed.

Calculation

$A = 2\sqrt{140 \times 2 \times 120} = 366$ mm
 $A/S = 366 / 120 = 3,05$ $K = 0,930$ (see table "K")
 $B = 0,930 \times 366 = 340$ mm

EXPLANATION OF FORMULA

- A = Exposed length of hose
- B = Installed length of hose (as illustrated)
- S = Lateral movement
- K = Factor, see table below
- R_n = min. c/l bend radius for flexing bend
- R_p = min. c/l bend radius for permanent bend

Table for K

A/S	2	2,5	3	3,5	4	4,5	5	6	7	8	9	10	11	12	13	≥ 14
K	0,825	0,897	0,928	0,947	0,960	0,970	0,975	0,985	0,990	0,993	0,994	0,995	0,996	0,997	0,997	0,998

ENGINEERING DATA

VERTICAL LOOP FOR MAXIMUM VERTICAL TRAVEL

The illustration on the right shows the proper method of installing hose in vertical loops. The formula and the table for "B" will aid in determining the overall length of an assembly.

Formula

$$\text{Overall length} = B + 0,5 \pi A + 0,5S$$

Data

Using 25 mm type BW856-1H hose with fittings attached.

Example

$A = 230 \times 2 = 460$ mm (2x "minimum c/l bend radius for flexing bend", see table type BW856).

$B = 410$ mm (from table "B")

$S = 200$ mm (desired movement)

Overall length = $410 + 0,5 \pi \cdot 460 + 100 = 1232,6$ mm or appr. 1235 mm.

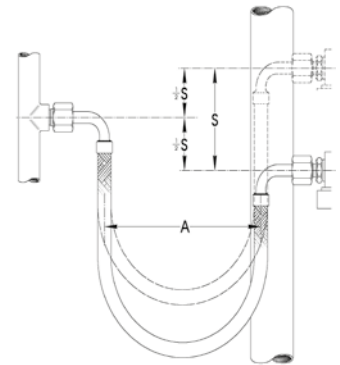

VERTICAL LOOP FOR SHORT HORIZONTAL TRAVEL

The formula and the table for "B" will aid in determining the overall length for an assembly when installed as illustrated in the drawing on the right.

Formula

$$\text{Overall length} = B + 0,5 \pi (A + S)$$

$$C = \frac{A + B + (0,5 \pi \cdot S)}{2}$$

Data

Using 10 mm type BW656-1S, with fittings attached.

Example

$A = 150 \times 2 = 300$ mm (2x min. c/l bend radius for flexing bend, see type BW 656).

$B = 280$ mm (from table "B")

$S = 250$ mm (desired movement)

Overall length = $280 + 0,5 \pi (300 + 250) = 1143,9$ mm or appr. 1145 mm.

$$C = \frac{300 + 280 + (0,5 \pi \cdot 250)}{2}$$

$C = 486,3$ mm or appr. 490 mm.

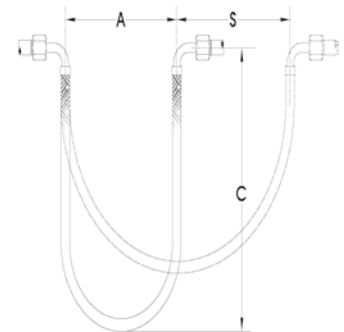

HORIZONTAL LOOP FOR MAXIMUM HORIZONTAL TRAVEL

The illustration on the right is another example of a typical installation of hose in which the movement is horizontal. The purpose of the support is to prevent the hose from sagging and causing failure near the fittings.

Formula

$$\text{Overall length} = B + 0,5 \pi \cdot A + 0,5S$$

Data

Using 12 mm type BW856-1H hose with fittings attached.

Example

$A = 2 \times 205 = 410$ mm (2x "minimum c/l bend radius for flexing bend", see type BW856)

$B = 10$ (from table "B")

$S =$ desired movement 550 mm

Overall length = $310 + (0,5 \pi \cdot 410) + (0,5 \times 550) = 1229$ mm or appr. 1230 mm.

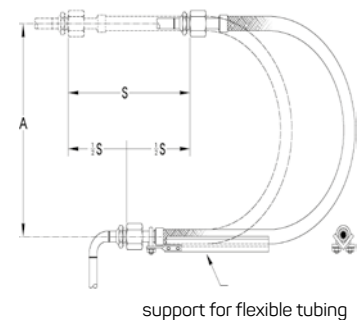

EXPLANATION OF FORMULA

A = Exposed length of hose

B = Installed length of hose (as illustrated)

S = Lateral movement

K = Factor, see table below

R_h = min. c/l bend radius for flexing bend

R_p = min. c/l bend radius for permanent bend

Table for B

INSIDE HOSE DIAMETER	MM	5-8	10	12-15	20	25	32	40	50	65	75	100	125	150	200	250
	INCH	1/4"	3/8"	1/2"	3/4"	1"	1.1/4"	1.1/2"	2"	2.1/2"	3"	4"	5"	6"	8"	10"
B	MM	230	280	310	360	410	460	510	560	610	660	760	840	910	1020	1170

ENGINEERING DATA

MISALIGNMENT AND OFFSET MOVEMENTS

For intermittent offset movement consult offset formula on page 9 and the "minimum c/l bend radius for flexing bend" columns in specifications for each type and size of corrugated hose.

For misalignment and ease of installation where there is no significant movement or vibration, consult offset formula on page 9 and "minimum c/l bend radius for permanent bend" columns in specifications for each type and size of corrugated hose.

MULTIPLE MOVEMENTS

To absorb movements in several directions and at several planes, a 90° flexible hose assembly is recommended, made up out of two short flexibles which are connected by a 90° pipe angle. At both ends of the assembly swivel flanges are used for connection to the piping system. This is important in order to avoid tension of the flexible hoses during installation. The required length of the hoses is determined by various movements. Torsion on account of these movements will then be absorbed by both hoses.

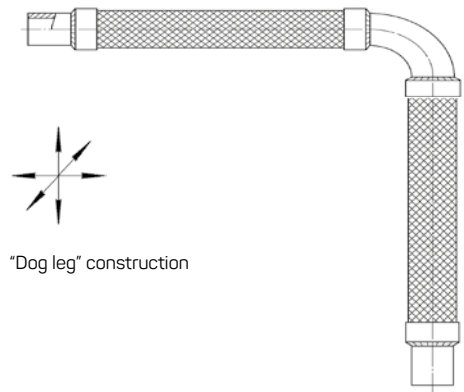

VIBRATION

Normal vibration encountered in average industrial applications is illustrated in the chart on the right.

Under these conditions the exposed length of hose (Dimension L, drawing at right), should never be shorter than length given in "min. exposed length for normal vibration" in specifications for each type and size of corrugated hose.

Definitions

Amplitude equals lateral displacement from c/l of hose. Double amplitude equals lateral displacement on both sides of hose or 2 times the amplitude.

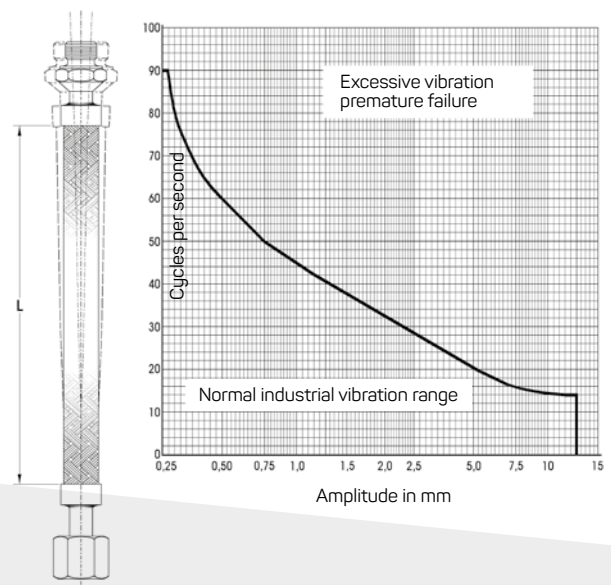

Corrosion resistance table

The following tables may be used only as a guide in the selection of the most suitable hose and fitting material for a given medium. The listed media are in general considered to be pure, at room temperature and, unless otherwise specified, dry. A change in any one of these conditions may change the rating. No attempt has been made to account for variations in service conditions since these variables are too innumerable and complex.

Additional information on service life, etc., is keyed to the notes behind the rating code A, B or C.

"Dry" can also be referred to as "anhydrous".

When there is a question about this reference table or you have unusual service conditions or media, contact us before ordering.

Rating code

- A - Suitable (normal condition)
- B - Limited Service
- C - Unsuitable

Notes

- 1 Susceptible to intergranular corrosion
- 2 May cause explosive reaction
- 3 Susceptible to stress corrosion cracking
- 4 Susceptible to pitting type corrosion
- 5 Discolors
- 6 Concentration over 50% and/or temperature over 95°C, refer to our engineering department.

	MONEL	CARBON STEEL	STAIN-LESS 304L/321	STAIN-LESS 316L
Acetaldehyde	A	B	A	A
Acetanilide	B	B	B	B
Acetic acid	B	C	B1	A1
Acetic anhydride	B	C	B	B
Acetone	A	C	B	B
Acetophenone	A	A	B	B
Acetylene	A	A	A	A
Acrylates	B	B	B	B
Acrylic acid	B	C	B	B
Acrylonitrile	A	A	A	A
Alcohols	A	A ⁵	A	A
Alum	B	C	B	B
Alumina	A	A	A	A
Aluminum acetate	B	C	B	B
Aluminum chloride - dry	A	B	A	A
Aluminum chloride - moist	B	C ³	C ^{3,4}	C ³
Aluminum fluoride	B	B	C	C
Aluminum hydroxide	B	B	A	A
Aluminum sulfate	B	C	B ^{1,3}	A ³
Ammonia - dry	A	A	A	A
Ammonia - moist	C	C ³	A	A
Ammonium acetate	A	A	A	A
Ammonium bromide	B	C	C ⁴	C ⁴
Ammonium chloride - dry	A	B	A	A
Ammonium chloride - moist	B	C	C ^{3,4}	C ³
Ammonium hydroxide 6	A	B	A	A
Ammonium nitrate	C ²	C ³	A	A
Ammonium sulfate	B	C	C ¹	B
Amyl acetate	A	A	A	A
Amyl alcohol	A	A	A	A

	MONEL	CARBON STEEL	STAIN-LESS 304L/321	STAIN-LESS 316L
Amyl chloride - dry	A	B	A	A
Amyl chloride - moist	B	C	C ^{3,4}	C ³
Aniline	A	C	B	B
Aniline dyes	A	C	B	B
Asphalt	A	A	A	A
Atmosphere - industrial	A	C	B ⁴	A ⁴
Atmosphere - marine	A	C	B ⁴	B ⁴
Atmosphere - rural	A	C	A	A
Barium carbonate	B	B	B	B
Barium chloride - dry	A	A	A	A
Barium chloride - moist	B	B	C ^{3,4}	C ³
Barium hydroxide	B	B	B	A
Barium sulfate	B	B	B	B
Barium sulfide	C	C	B	B
Beer	A	C	A	A
Beet sugar syrups	A	B	A	A
Benzaldehyde	B	C	B	B
Benzene (Benzol)	A	A	A	A
Benzoic acid	B	C	A	A
Benzylamine	B	B	B	B
Benzyl chloride - dry	A	B	A	A
Benzyl chloride - moist	B	C	C ^{3,4}	C ³
Black liquor, sulfate process	A	C	B	B
Bleaching powder - dry	A	C	A	A
Bleaching powder - moist	B	C	C ^{1,3,4}	C ^{3,4}
Borax	A	B	A	A
Bordeaux mixture	A	B	A	A
Boric acid	B	C	A	A
Boron trichloride - dry	B	A	B	B
Boron trichloride - moist	B	B	C ^{3,4}	C ³
Boron trifluoride - dry	B	A	B	B

Corrosion resistance table

Rating code

- A - Suitable (normal condition)
- B - Limited Service
- C - Unsuitable

Notes

- 1 Susceptible to intergranular corrosion
- 2 May cause explosive reaction
- 3 Susceptible to stress corrosion cracking
- 4 Susceptible to pitting type corrosion
- 5 Discolors
- 6 Concentration over 50% and/or temperature over 95°C, refer to our engineering department.

	MONEL	CARBON STEEL	STAIN-LESS 304L/321	STAIN-LESS 316L
Brines	B	C	C ^{3,4}	C ³
Bromic acid	C	C	C	C
Bromine - dry	A	C	B	B
Bromine - moist	B	C	C	C
Butadiene	A	A	A	A
Butane	A	A	A	A
Butanol (butyl alcohol)	A	A ⁵	A	A
Butyl phenols	A	B ⁵	B	B
Butylamine	A	A	A	A
Butyric acid	B	C	B	B
Cadmium chloride - moist	B	C	C ^{3,4}	C ³
Cadmium chloride - dry	A	A	A	A
Cadmium sulfate	A	B	A	A
Calcium bisulfite	B	B	B ¹	B
Calcium bromide	B	C	C ³	C ³
Calcium chloride - moist	B	C	C ^{3,4}	C ³
Calcium chloride - dry	A	A	A	A
Calcium fluoride	B	C	C	C
Calcium hydroxide	B	C	B	B
Calcium hypochlorite - moist	B	C	C ^{3,4}	C ^{3,4}
Calcium hypochlorite - dry	A	B	A	A
Calcium nitrate	B	C ¹	B ¹	B
Calcium oxide	A	A	A	A
Cane sugar syrups	A	B	A	A
Carbolic acid (phenol)	B	C	B	A
Carbon dioxide - dry	A	A	A	A
Carbon dioxide - moist	A	C	A	A
Carbonated beverages	A	C	A	A
Carbonated water	A	C	A	A
Carbon disulfide	B	B	B	B
Carbon tetrachloride - dry	A	B	A	A
Carbon tetrachloride - moist	B	C	C ^{3,4}	C ⁴
Castor oil	A	A	A	A
Chlorine - dry	A	B	A	A
Chlorine - moist	B	C	C ^{3,4}	C ³
Chloroacetic acid	B	C	C ^{3,4}	C ³
Chloric acid	C	C	C ³	C ³
Chlorine dioxide - dry	A	B	A	A
Chlorine dioxide - moist	B	C	C ^{3,4}	C ³

	MONEL	CARBON STEEL	STAIN-LESS 304L/321	STAIN-LESS 316L
Chloroform - dry	A	A	A	A
Chloroform - moist	B	C	C ^{3,4}	C ³
Chromic acid	B	C ³	C ^{1,4}	B
Chromic fluorides	B	C	C	C
Chromic hydroxide	B	B	B	B
Chromium sulfate	B	C	B	B
Cider	A	C	A	A
Citric acid	B	C	B	B
Coffee	A	C	A	A
Copper chloride - dry	A	B	A	A
Copper chloride - moist	B	C	C ^{3,4}	C ³
Copper nitrate	C	C	A	A
Copper sulfate	B	C	B ¹	B
Corn oil	A	A	A	A
Cottonseed oil	A	A	A	A
Creosole	A	A	A	A
Crude oil	A	C	C ¹	B
Cyclohexane	B	B	B	B
DDT	B ⁴	C	A	A
Dichloroethane - dry	A	A	A	A
Dichloroethane - moist	B	C	C ⁴	C ⁴
Dichloroethylene - dry	A	B	A	A
Dichloroethylene - moist	B	C	C ⁴	C ⁴
Dichlorophenol	B	C	B ³	B ³
Diisocyanate	A	B	A	A
Dimethyl sulfate	B	B	B	B
Epichlorohydrin - dry	A	C ⁴	A	A
Epichlorohydrin - moist	B	C ⁴	C ^{3,4}	C ³
Ethane	A	A	A	A
Ethers	A	B	A	A
Ethyl acetate	B	B	B	B
Ethyl alcohol	A	A	A	A
Ethyl benzene	B	B	B ³	B
Ethyl chloride - dry	A	A	A	A
Ethyl chloride - moist	B	C	C ^{3,4}	C ³
Ethylene	A	A	A	A
Ethylene chlorohydrin - dry	A	B	A	A
Ethylene chlorohydrin - moist	B	C	C ⁴	C ⁴
Ethylene diamine	B	B	B	B
Ethylene glycol	A	A	A	A
Ethylene oxide	B	B	A	A

Corrosion resistance table

	MONEL	CARBON STEEL	STAIN-LESS 304L/321	STAIN-LESS 316L
Fatty acids	B	C	B ^{1,4}	A
Ferric chloride - dry	A	B	A	A
Ferric chloride - moist	B	C	C ^{1,3,4}	C ^{3,4}
Ferric nitrate	C	C	B	B
Ferric sulfate	C	C	B ¹	A
Ferrous chloride - dry	A	B	A	A
Ferrous chloride - moist	B	C	C ^{3,4}	C ³
Ferrous sulfate	A	C	B ⁴	B
Fluorine - dry	A	A	A	A
Fluorine - moist	B	C	C	C
Formaldehyde	A ⁵	B ⁵	B	B
Formic acid	B	C	B ¹	A
Freon	A	A	A	A
Fruitjuices	A	C	A	A
Fuel oil	A	C	A	A
Furfural	A	B	A	A
Gasoline	A	B	A	A
Gelatine	A	C	A	A
Glucose	A	B	A	A
Glue	A	C	A	A
Glutamic acid	E ³	C	B ^{3,4}	B ^{3,4}
Glycerin (glycerol)	A	B ⁵	A	A
Heptane	A	A	A	A
Hexachloroethane - dry	A	B	A	A
Hexachloroethane - moist	B	C	C ⁴	C ⁴
Hydrazine	C	C	A	A
Hydrobromic acid	C	C	C ⁴	C
Hydrocarbons, pure	A	A	A	A
Hydrochloric acid	B	C	C ⁴	C ⁴
Hydrocyanic acid	B	C ³	C ^{1,3}	C ³
Hydrofluoric acid	B	C	C ^{1,3}	C
Hydrofluorsilicic acid	B	C	C	C
Hydrogen	A	A	A	A
Hydrogen chloride - dry	A	B	A	A
Hydrogen chloride - moist	B	C	C ⁴	C ⁴
Hydrogen peroxide	C	C	B	B
Hydrogen sulfide - dry	A	B	A	A
Hydrogen sulfide - moist	E ³	C ³	B ⁴	A
Hydroquinone	B	B ⁵	B	B
Kerosine (kerosene)	A	B	A	A
Lacquers	A	A	A	A
Lacquer solvents	A	A	A	A
Lactic acid	B	C	B ^{1,4}	B ¹
Lime	A	B	A	A
Lime - sulfur	B	C	B	B
Linseed oil	A	B	A	A
Lithium chloride - dry	A	B	A	A
Lithium chloride - moist	B	B	C ^{3,4}	C ³
Lithium hydroxide	B	B	B	B

	MONEL	CARBON STEEL	STAIN-LESS 304L/321	STAIN-LESS 316L
Magnesium chloride - dry	A	B	A	A
Magnesium chloride - moist	B	C	C ^{3,4}	C ³
Magnesium hydroxide	A	A	A	A
Magnesium sulfate	A	B	B	A
Maleic acid	B	B	B ¹	B
Mercuric chloride - dry	A	B	A	A
Mercuric chloride - moist	B	C	C ^{3,4}	C ³
Mercurous nitrate	B ³	B	B	B
Mercury	B ³	B	B	B
Methyl alcohol	A	A	A	A
Methane	A	A	A	A
Methyl chloride - dry	A	A	A	A
Methyl chloride - moist	B	C	C ^{3,4}	C ³
Methyl ethyl ketone	B	B	B	B
Milk	A	C	A	A
Mine water	B	C	B	B
Napthalene	B	A	A	A
Natural gas	A	A	A	A
Nickel chloride - dry	A	B	A	A
Nickel chloride - moist	B	C	C ^{3,4}	C ³
Nitric acid	C	C	A	A
Nitrotoluene	B	B	B	B
Nitrogen	A	A	A	A
Oleic acid	A	C	B ⁴	B
Oleum (fuming H2SO4)	C	B ³	B	B
Axalic acid	B	C	C ¹	B ¹
Oxygen	A	C	A	A
Palmitic acid	A	C	A	A
Parafin	A	B	A	A
Pentane	B	B	B	B
Phenol (carbolic acid)	B	C	B	A
Phosphoric acid	B	C	C ¹	B ¹
Phthalic acid	B	C	B ¹	B
Pitric acid	C	C	B	B
Potassium bromide	B	C	C	C
Potassium carbonate	A	B	A	A
Potassium chloride - dry	A	A	A	A
Potassium chloride - moist	B	C	C ^{3,4}	C ³
Potassium chromate	B	C	B	B
Potassium cyanide	A	B	B	B
Potassium dichromate	A	C	A	A
Potassium fluoride	B	C	C	C
Potassium hydroxide	A ³	B ³	B ³	A
Potassium nitrate	B	B	B	A
Potassium perman-ganate	B	B	B	B
Potassium sulfate	B	C	B	B
Propane	A	A	A	A

Corrosion resistance table

Rating code

- A - Suitable (normal condition)
- B - Limited Service
- C - Unsuitable

Notes

- 1 Susceptible to intergranular corrosion
- 2 May cause explosive reaction
- 3 Susceptible to stress corrosion cracking
- 4 Susceptible to pitting type corrosion
- 5 Discolors
- 6 Concentration over 50% and/or temperature over 95°C, refer to our engineering department.

	MONEL	CARBON STEEL	STAIN-LESS 304L/321	STAIN-LESS 316L
Propylene	A	A	A	A
Propylene oxide	C	C	A	A
Propylene dichloride - dry	A	B	A	A
Propylene dichloride - moist	B	C	C ⁴	C ⁴
Pyridine	B	B5	B	B
Pyrrolidine	B	B	B	A
Quinine	B	C	B	B
Rosin	A	C5	A	A
Sea water	B	C	C ^{3,4}	C ³
Sewage	A	B	A	A
Silver salts	A	C	B	B
Silver nitrate	C	C ³	B	A
Soap solutions	A	B	A	A
Sodium	A	A	A	A
Sodium acetate	B	B	B ⁴	B
Sodium bicarbonate	A	C	A	A
Sodium bisulfate	B	C	B ^{1,4}	A
Sodium bisulfite	B ⁴	C	B	B
Sodium bromide	B	B	C	C
Sodium carbonate	A	B	A	A
Sodium chlorate - dry	A	A	A	A
Sodium chlorate - moist	B	C	C ^{3,4}	C ³
Sodium chloride - dry	A	B	A	A
Sodium chloride - moist	B	C	C ^{3,4}	C ³
Sodium chromate	A	B	A	A
Sodium citrate	B	B	B	B
Sodium cyanide	B	B	B	B
Sodium dichromate	B	C	A	A
Sodium fluoride	A	B	C ⁴	C
Sodium hydroxide 6	A	B ³	B ³	B ³
Sodium hypochlorite - dry	A	B	A	A
Sodium hypochlorite - moist	B	C	C ^{1,4}	C ⁴
Sodium metasilicate	A	B	A	A
Sodium nitrate	A	B ³	A	A
Sodium nitrite	B	B	B	B
Sodium peroxide	B	C	A	A
Sodium phosphate	A	C	A	A
Sodium silicate	A	B	A	A
Sodium sulfate	A	B	B3	B
Sodium sulfide	A	C	B4	B
Sodium sulfite	A	C	B	B

	MONEL	CARBON STEEL	STAIN-LESS 304L/321	STAIN-LESS 316L
Sodium thiosulfate	A	C	B	B
Stannic chloride - dry	A	B	A	A
Stannic chloride - moist	B	C	C ^{3,4}	C ³
Stannous chloride - dry	A	B	A	A
Stannous chloride - moist	B	C	C ^{3,4}	C ³
Steam	A ³	C	A	A
Stearic acid	B	C ⁵	B	B
Strontium nitrate	B	C	B	B
Sulfate black liquor	B	B	B	B
Sulfate green liquor	B	B	B ³	B
Sugar solutions	A	B	A	A
Sulfur - dry	A	B	A	A
Sulfur - molten	C	C	C	B
Sulfur chloride - dry	A	C	A	A
Sulfur chloride - moist	B	C	C ^{3,4}	C ³
Sulfur dioxide - dry	B	C	C ¹	B
Sulfur dioxide - moist	C	C	C ¹	B
Sulfur trioxide - dry	A	C	A	A
Sulfuric acid, 95-100%	B	B	A	A
Sulfuric acid, 80- 95%	B	C	B	B
Sulfuric acid, 40- 80%	C	C	C ¹	C ¹
Sulfuric acid, 40%	C	C	C ¹	C ¹
Sulfurous acid	B	C	C ^{1,4}	C ^{1,4}
Tail oil	B	B	B	B
Tannic acid	B	C5	B	B
Tar	A	B	A	A
Tartaric acid	B	C	B	B
Tetraphosphoric acid	C	C	B	B
Toluene	A	A	A	A
Trichloroethane - dry	A	A	A	A
Trichloroacetic acid	B	C	C ^{3,4}	C ⁴
Trichloroethane - moist	B	C	C ⁴	C ⁴
Trichloroethylene - dry	A	A	A	A
Trichloroethylene - moist	B	C	C4	C4
Turpentine	A	B	A	A
Varnish	A	B	A	A
Vinegar	B	C	A	A
Water, potable	A	C	A	A
Xylene	A	B	A	A
Zinc chloride - dry	A	A	A	A
Zinc chloride - moist	B	C	C ^{3,4}	C ³
Zinc sulfate	B	C	B	A

Anamet Engineering

- Design support
- Advise
- Drawings
- Test Specifications
- Certification (Material, testing e.g.)

Products



Expansion joints (Bellows)
E.g. District heating & Power stations



(Heat) pump connections
Other connections can be advised by our Sales Engineer



Special welded / casted pump connections
Anamet provides special bend and welded connection to customer specifications



Anaflow PTFE hose for liquids



High pressure mist hoses



GMA gas meter connections



 **ANAMET EUROPE**

ANAMETEUROPE.COM

GALWIN 5 1046 AW AMSTERDAM
+31 (0)20 5863586
SALES@ANAMET.NL